

EGV-9B v1

80 to 10m QRP CW Transceiver KIT

MAIN BOARD

Assembly manual

Last update April 01, 2023

ea3gcy@gmail.com

Latest updates and news in: www.ea3gcy.com

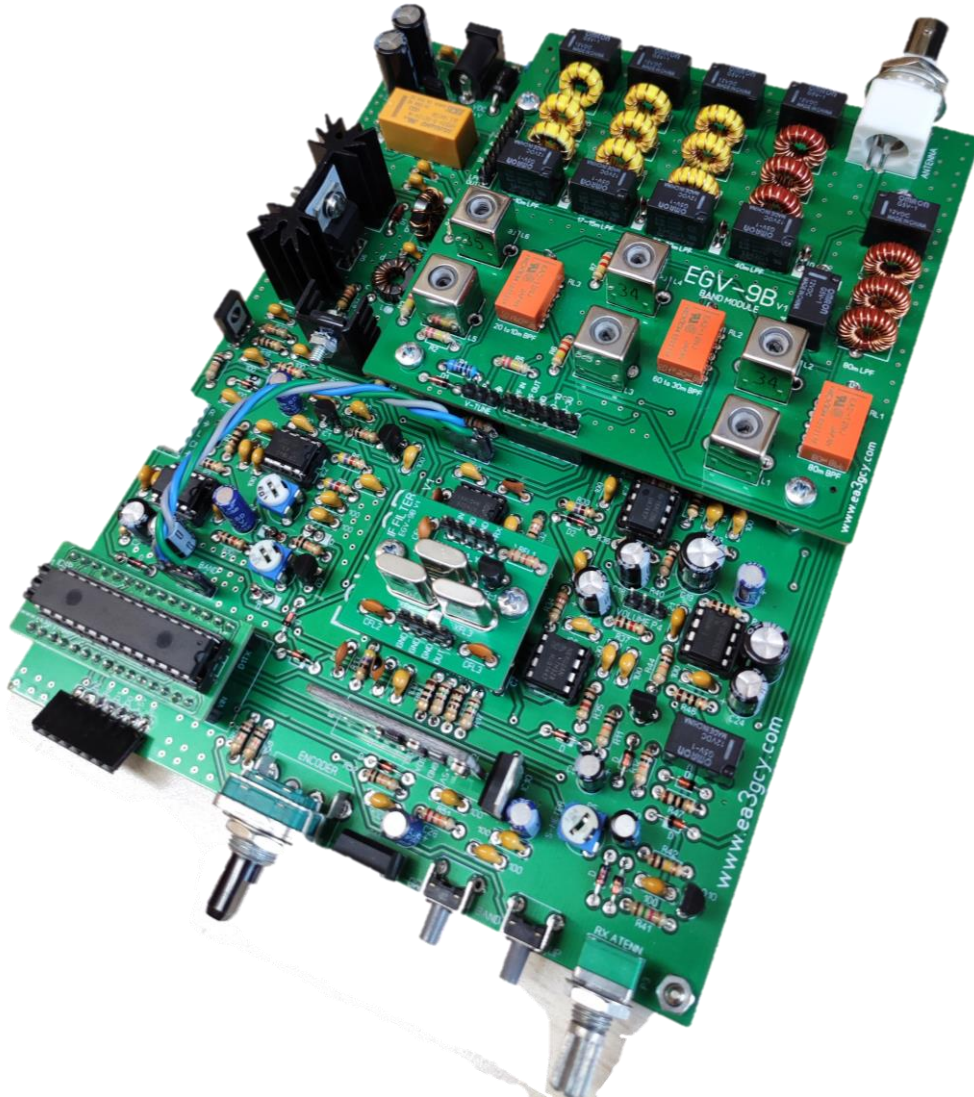

Thank you for building the **EGV-9B v1** 80 to 10m QRP CW Transceiver kit

Have fun assembling it and enjoy QRP! 73 Javier Solans, EA3GCV

INTRODUCTION

This EGV-9B transceiver is probably the kit that I have produced with more care and illusion in my life. It is a great honor to name this kit "EGV", the callsign suffix of the late Miguel Montilla, EA3EGV (SK).

With no doubt, this is the kind of kit he liked most.

It was my privilege to establish and share with him the first years of the EA-QRP Club. He has always been a referent in my life; when I remember those wonderful years his humbleness, work capacity and generosity are the virtues which shine his image.

How lucky I was to be able to share the path with you, Miguel. Thanks!

Javier Solans, ea3gcy

Miguel Montilla, EA3EGV (SK)

Miguel got his A class callsign in 1983. He hold previously the call EC3BAY. He was a good CW operator, highly respected among their peers. Holder of many awards and winner of several contests, Miguel enjoyed both the competition and sharing his time with a novel operator, patiently providing information to make a QSO.

He published articles on the journal from URE (Spanish Radio Amateur Union) Unión de Radioaficionados Españoles, on "CQ Radio Amateur" (Spanish edition) and on the G-QRP bulletins, etc. But, without doubt, what he liked most it was QRP kit building. He loved to build a kit over a weekend and enjoy some placid QSOs made with his new fresh transceiver. Of course, always with the minimum power required!

Miguel EA3EGV was the founder member #1 of the EA-QRP CLUB.

On September 1994 a group of four hams, Miguel Montilla EA3EGV, Miguel Molina EA3FHC, Vicenç Llarío EA3ADV and myself, Javier Solans EA3GCY, founded the EA-QRP.

EGV-9B

The *EGV-9B* is the evolution of the legendary EGV+ kit.

The *EGV-9B* is a 80 to 10m QRP CW transceiver design based on the NE602 integrated circuit used as a receiving mixer and CW demodulator. Band and TX / RX switching, audio mute etc. they are controlled by an ATMEGA328 processor (Arduino NANO compatible).

The *EGV-9B* is a very versatile design. To facilitate assembly and experimentation, the circuit is developed on a main board and a plug-in board with the low-pass and band-pass filters. The Local Oscillator, BFO and CW TX signal are generated by a SI-5351 module that is controlled by the ATMEGA328 processor. Frequency and other performance data is displayed on a 1.3 "OLED screen. The CW transmit signal is generated and keyed directly, there are no heterodyning or mixing with other signals. The IF crystal filter is also mounted on a small plug-in board, which makes experimentation easier.

The *EGV-9B* includes features like CW keyer and beacon, audio Mute, six frequency steps in two ranges, S-Meter and RIT. Separate adjustments for headphone, speaker, RX volume, and sidetone volume. Setting menus for BFO, SI5351 Xtal adjust, voltmeter adjust etc.

There are only five controls: Frequency tuning, Band tuning, Volume, RF attenuator and two UP-DOWN band switches.

KB-2 automatic keyer circuit is included on EGV-9B board. It offers iambic A and B mode, 4 memories and various settings (speed adjustment, adjustable lateral tone, tune function, beacon, straight keyer, etc).

**Note: good experience on radio assembly is required.
It shouldn't be your first transceiver to build.**

All SMD parts soldered at the factory. You don't have to solder anything SMD

SPECIFICATIONS

GENERAL:

Frequency coverage:

80-60-40-30-20-17-15-12-10m

Note: You can tune below and above the bands (from 3 to 30MHz) but downgrading the characteristics

Tuning steps on two ranges: 10Hz-100Hz-1kHz and 10kHz-100kHz-1MHz.

Modes: CW.

RIT function: Without frequency limit

Power requirements: 10 – 14VDC, 1 – 2A transmit, 0.15 – 0.25A receive.

Antenna impedance: 50 ohms nominal.

Controls: Tuning with pushbutton. Band-pass adjust. Volume. RF attenuator. UP-DOWN band switches.

Board dimensions: 180 x 140 mm.

Weight: (no enclosure): 0.35 kg.

TRANSMITTER:

Mode: CW (direct frequency, without heterodyning or mixing)

RF output: 3 to 6W @13.8V (depends on band)

Output TX Amp: C class amplifier.

Harmonics output: -45dBc or better below the fundamental frequency (excepted 60 and 17m)

Other spurious signals: -50dBc or better below the fundamental frequency.

T/R switching: Relays.

RECEIVER:

Type: Superheterodyne. Balanced mixers.

Sensitivity: 0.4uV minimum discernible signal average (according band).

Selectivity: 3-pole crystal ladder filter, 800Hz nominal bandwidth.

IF frequency: 4.915MHz.

AGC: acts on the receive path according to the received audio level.

Audio output: 250mW for 4-8 ohms speaker.

Individual adjustment for headphones and sitetone.

**PLEASE READ ALL ASSEMBLY INSTRUCTIONS COMPLETELY AT
LEAST ONCE BEFORE YOU BEGIN.**

LIST OF COMPONENTS BY VALUE/QUANTITY

Resistors list				
Qty	Value	Checked	Ref.	Identified
4	10 Ω		R7, R14, R46, R47	brown-black-black
4	22 Ω		R23, R24, R32, R34	red-red-black
10	100 Ω		R1, R2, R3, R8, R16, R19, R39, R45, R49, R50	brown-black-brown
2	150 Ω		R15, R17	brown-green-brown
1	330 Ω		R22	orange-orange-brown
3	470 Ω		R13, R33, R43	yellow-violet-brown
6	1K		R10, R20, R27, R35, R37, R48	brown-black-red
1	1K5		R41	brown-green-red
1	2K2		R21	red-red-red
2	4K7		R5, R6	yellow-violet-red
21	10K		R4, R9, R11, R12 R18, R25, R36, R40, R44, R52, R53, R54, R55, R56, R57, R58, R59, R60, R61, R62, R63	brown-black-orange
1	22K		R51	red-red-orange
5	100K		R26, R28, R29, R30, R42	brown-black-yellow
2	220K		R31, R38,	red-red-yellow
Potentiometers list				
2	100		Adjustable RM-063 P6, P7	103
2	10K		Adjustable RM-065 P1, P2	101
1	100K		Adjustable RM-065 P5	104
1	1K		Shaft potentiometer P3	B1K
1	10K		Shaft potentiometer P4	B10K
Encoder				
1	Encoder		PEC16-4015F Encoder	--

Capacitors list				
Qty	Value	Checked	Ref.	Identified
100n capacitors				
47	100n		All printed "100" on PCB	104 or 0.1
Other capacitors				
2	10n		C9, C21	103 or 0.01
4	1n		C8, C10, C12, C17	102 or 0.001
1	220p		C15	220 or 221
1	82p		C7	82
1	22p		C14	22
1	15p		C6	15
1	1uf		C5	1uf
2	4,7uf		C13, C20 (C13 miniature format)	4,7uf
6	10uf		C1, C4, C11, C22, C27, C28 (C11 miniature format)	10uf
5	100uf		C2, C3, C16, C18, C24,	100uf
2	470uf		C19, C23, C25, C26	470uf

Semiconductor list				
Qty	Type	Checked	Ref.	Identified
Transistors				
12	BC547		Q1, Q2, Q3, Q7, Q10, Q11, Q12, Q13, Q14, Q15, Q16, Q17	C547
2	2N7000		Q8, Q9	2N7000
1	BD140		Q4	BD135 or C2314 or NTE295
1	BD135 / C2314 / NTE295		Q5	BD140
1	2SC1969		Q6	SC1969
ICs				
2	78L05		IC1, IC4	78L05
1	7809		IC10	7809
1	7805		IC11	7805
2	LM386		IC3, IC8	LM386
1	UA741		IC7	UA741
2	NE602 (SA602)		IC5, IC6	NE602
1	KB-2 CW keyer		IC2	PIC12F(LF)1840
1	CD74HC238		IC9	HC238
1	SI5351		IC12	SI5351 module
1	ATMEGA328P		IC14	ATMEGA328P module
1	OLED DISPLAY		IC13	OLED 1.3"
Diodes				
24	1N4148		All diodes printed "D" on PCB are 1N4148	4148
Other diodes				
1	47V 1W Zener		D1	47V or 1N4756
1	6V2 Zener		D2	6V2 or 1N5234
1	BY255		D3	BY255

RF Transformers/Relays				
Qty	Part/Value	Checked	Ref.	Identified
2	FT37-43		L1, L2	black toroid
1	Huigang relay		RL1a/b	Huigang HRS2H 12V
1	Omron relays		RL2	Omron G5V-1 12V

Connectors and Hardware				
Qty	Part/Value	Checked	Ref.	Identified
2	Jack socket		Stereo PCB Jack 3.5mm socket	--
1	Supply socket		Power supply PCB Jack 2.1mm socket	--
2	UP-DOWN Switch		Mini Push switches for UP and DOWN band	--
1	Switch		DPDT PCB slide switch EG2219	--
2	Female pins		15 pin female sockets strip (Arduino)	--
22	Female pins		8 + 6 + 4 + 4 Female strip pins	--
1	Male pins		5 pin male strip polarized socket	--
6	IC sockets		8 pins IC sockets	--
1	IC socket		16 pins IC socket	
13	Male pins strip		3 + 3 + 3 + 2 + 2 no polarized strip male pins	--
2	45° strip pins		7 pin 45° bent strip (to SI5351 and OLED modules)	--
1	Jumper		Jumper to J1 (ON/OFF)	--
1	Heatsink		Heatsink to Q5	--
1	Heatsink		Heatsink to Q6	--
2	Mica insulator		Mica insulator to Q5 and Q6	--

1	Plastic washer		Plastic through isolator washer to Q3 screw	--
2	M3x10 screw		10mm M3x10 screw to Q5 and Q6 and LPF/BPF board	--
10	M3x4 screws		4mm M3x4 screws	--
12	M3 nuts		M3 nuts	--
2	M3 washer		Metal M3 washer to Q5 and Q6	--
6	M3 spacers		Hex 10mm M3 spacers	--
60	60 cm.		60 cm. 0,4mm enamelled wire	--
1	PCB		EGV-3B Main PCB (printed circuit board)	EGV-9B v1

LIST OF INDIVIDUAL COMPONENTS

Resistors						
Checked	Ref.	Value	Ident./Comment	Circuit section	Located	
	R1	100 Ω	brown-black-brown	Keyer	L-2	
	R2	100 Ω	brown-black-brown	Keyer	L-2	
	R3	100 Ω	brown-black-brown	Keyer	M-2	
	R4	10K	brown-black-orange	Keyer	K-5	
	R5	4K7	yellow-violet-red	Sidetone	L-5	
	R6	4K7	yellow-violet-red	Sidetone	L-5	
	R7	10 Ω	brown-black-black	Sidetone	N/O-1	
	R8	100 Ω	brown-black-brown	Sidetone	G-11	
	R9	10K	brown-black-orange	Switches	N-5	
	R10	1K	brown-black-red	Switches	N-3	
	R11	10K	brown-black-orange	Switches	O-12	
	R12	10K	brown-black-orange	Switches	O-12/13	
	R13	470 Ω	yellow-violet-brown	VFO out (CLK0)	O/P-7	
	R14	10 Ω	brown-black-black	BFO out (CLK1)	O/P-8	
	R15	150 Ω	brown-green-brown	BFO out (CLK1)	O/P-9	
	R16	100 Ω	brown-black-brown	BFO out (CLK1)	O/P-9	
	R17	150 Ω	brown-green-brown	BFO out (CLK1)	O/P-9	
	R18	10K	brown-black-orange	TK key	K-1	
	R19	100 Ω	brown-black-brown	Driver	J-1/2	
	R20	1K	brown-black-red	Driver	J-2/3	
	R21	2K2	red-red-red	Driver	J-3/4	
	R22	330 Ω	orange-orange-brown	Driver	J-2	
	R23	22 Ω	red-red-black	Driver	J-5	
	R24	22 Ω	red-red-black	Output Amp	H-3	
	R25	10K	brown-black-orange	AGC	C-12	
	R26	100 K	brown-black-yellow	AGC	D-12	
	R27	1K	brown-black-red	AGC	E-12	
	R28	100K	brown-black-yellow	AGC	F-12	
	R29	100K	brown-black-yellow	AGC	F-12	
	R30	100K	brown-black-yellow	AGC	F-13	
	R31	220K	red-red-yellow	AGC	F-13	
	R32	22 Ω	red-red-black	RX Mix	L-9	
	R33	470 Ω	yellow-violet-brown	NE602 power	K-9/10	
	R34	22 Ω	red-red-black	CW Dem.	M-10	
	R35	1K	brown-black-red	CW Dem.	N/O-11	
	R36	10K	brown-black-orange	Audio Preamp.	K-11	
	R37	1K	brown-black-red	Audio Preamp.	M-11	
	R38	220K	red-red-yellow	Audio Preamp.	J-11	
	R39	100 Ω	brown-black-brown	Audio Preamp.	J-12	
	R40	10K	brown-black-orange	Audio Preamp,	L-11/12	
	R41	1K5	brown-green-red	S-Meter	Q-13	
	R42	100K	brown-black-yellow	S-Meter	P-13	
	R43	470 Ω	yellow-violet-brown	S-Meter	K-12	
	R44	10K	brown-black-orange	Audio Amp.	M-12	
	R45	100 Ω	brown-black-brown	Audio Amp.	L-13	
	R46	10 Ω	brown-black-black	Audio Amp.	N-13	
	R47	10 Ω	brown-black-black	Audio Amp.	O-13	
	R48	1K	brown-black-red	Audio mute	I-10	
	R49	100 Ω	brown-black-brown	Headphones	B-4/5	
	R50	100 Ω	brown-black-brown	Headphones	B-7	
	R51	22K	red-red-orange	Digital section	Q-9/10	
	R52	10K	brown-black-orange	Digital section	Q-8	

		R53	10K	brown-black-orange	Digital section	Q/R-5
		R54	10K	brown-black-orange	Digital section	Q/R-6
		R55	10K	brown-black-orange	Digital section	J-7
		R56	10K	brown-black-orange	Digital section	J-7
		R57	10K	brown-black-orange	Digital section	J/I-7
		R58	10K	brown-black-orange	Digital section	G/H-5
		R59	10K	brown-black-orange	Digital section	G/H-6
		R60	10K	brown-black-orange	Digital section	G/H-7
		R61	10K	brown-black-orange	Digital section	G/H-7
		R62	10K	brown-black-orange	Digital section	G/H-8
		R63	10K	brown-black-orange	Digital section	G/H-9
Potentiometers list						
		P1	10K	10K adjustable 103 RM-065	Sidetone level	M-4
		P2	10K	10K adjustable 103 RM-065	TX decay	N-4
		P3	1K	Shaft potentiometer 102	RX Attenuator	R-13
		P4	10K	Shaft potentiometer 103	Volume	M-11
		P5	100K	100K adjustable 104RM-065	S-Meter level	P-12
		P6	100 Ω	100 Ω adjustable 101 RM-063	Audio Headphones	A-4/5
		P7	100 Ω	100 Ω adjustable 101 RM-063	Sidetone Headphones	A-7
Encoder						
		ENCODER	PEC16F	PEC16-4015F Encoder	ATMEGA328P	R-7

Capacitors						
Checked	Ref.	Value	Ident./Comment	Circuit section	Located	
	printed "100"	100n	(47) All printed "100" on PCB Identified as 104 or 0.1	--	See map	
	C1	10uf	10uf	Keyer	K-3	
	C2	100uf	100uf	Keyer	O-1	
	C3	100uf	100uf	Keyer	O-2	
	C4	10uf	10uf	Switches	N-3	
	C5	1uf	1uf	Switches	O/P-12	
	C6	15p	15	VFO	O/P-7	
	C7	82p	82	BFO	N/O-9/10	
	C8	1n	102	CW IN	O/P-6	
	C9	10n	103	Driver	K-3/4	
	C10	1n	102	Driver	I-4/5	
	C11	10uf	10uf Miniature format	AGC	G-13	
	C12	1n	102	AGC	D-13/14	
	C13	4,7uf	4,7uf Miniature format	AGC	E/F-13	
	C14	22p	22	RX Mix	K-8	
	C15	220p	220 or 221	RX Mix	L-7	
	C16	100uf	100uf	NE602	L-10/11	
	C17	1n	102	Audio Preamp.	J-11	
	C18	100uf	100uf	Audio Preamp.	L-11	
	C19	470uf	470uf	Audio Preamp.	K/L-12	
	C20	4,7uf	4,7uf	S-Meter	P-12/13	
	C21	10n	103	Audio Amp.	L/M-12	
	C22	10uf	10uf	Audio Amp	K/L-13	
	C23	470uf	470uf	Audio Amp.	L-14	
	C24	100uf	100uf	Audio Amp.	M-14	
	C25	470uf	470uf	Power Supply	A-1/2	
	C26	470uf	470uf	Power Supply	B-1/2	
	C27	10uf	10uf	Digital section	Q-11	
	C28	10uf	10uf	Digital section	R-9	

Semiconductors						
Checked	Ref.	Type	Ident./Comment	Circuit section	Located	
Transistors						
	Q1	BC547	BC547	Keyer	K-5	
	Q2	BC547	BC547	Switches	N-5	
	Q3	BC547	BC547	Switches	N-12	
	Q4	BD140	BD140	CW TX key	J-1	
	Q5	BD135	BD135	Driver	J-3/4	
	Q6	2SC1969	C1969	Out. Amp.	G-2	
	Q7	BC547	BC547	AGC	D-12	
	Q8	2N7000	2N7000	AGC	G-12	
	Q9	2N7000	2N7000	AGC	G-12	
	Q10	BC547	BC547	S-Meter	Q-14	
	Q11	BC547	BC547	Audio mute	C/D-14	
	Q12	BC547	BC547	Band switches	G-5	
	Q13	BC547	BC547	Band switches	G-6	
	Q14	BC547	BC547	Band switches	G-7	
	Q15	BC547	BC547	Band switches	G-7/8	
	Q16	BC547	BC547	Band switches	G-8	
	Q17	BC547	BC547	Band switches	G-9	
IC's						
	IC1	78L05	78L05	Keyer	K-4	
	IC2	KB-2 CW keyer	12F1840	KB-2Keyer	L-4	
	IC3	LM386	LM386	Sidetone	N-2	
	IC4	78L05	78L05	AGC	G-13	
	IC5	NE602	NE602 or SA602	RX mixer	L-8	
	IC6	NE602	NE602 or SA602	CW Dem	N-10	
	IC7	UA741	741	Audio Premp.	K-11	
	IC8	LM386	LM386	AudioAmp.	M-13	
	IC9	CD74HC238	HC238	And switches	I-7	
	IC10	7809	7809	Digital supply	P/Q-10	
	IC11	7805	7805	Digital supply	R-9	
	IC12	SI5351 Module	SI5351	Signals generator	P-8/9	
	IC13	OLED display	1.3" display	Display	R-2/3	
	IC14	ATMEGA328 module	ATMEGA328 module or Arduino NANO	Micro-controller	Q-3/4	
Diodes						
	Printed "D"	All diodes printed "D" on PCB are 1N4148 Identified as 4148		--	--	
	D1	47V 1W zener	47V or 1N4756	Output Amp.	F-2	
	D2	6V2 zener	6V2 or 1N5234	NE602 supply	K-10	
	D3	BY255	BY255	VCC protect	A/B-4	

Inductors/RF Transformers/Relay						
Checked	Ref.	Value/Type	Ident./Comment	Circuit section	Located	
	L1	FT37-43	Toroid 3-10 turns		G/H-3	
	L2	FT37-43	Toroid 8+8 turns		F-3/4	
Relays						
	RL1	RL1a/b	Huigang HRS2H 12V		C/D-3	
	RL2	RL2	Omron G5V-1 12V		N/O-13	

252-QUADRANT COMPONENT LAYOUT MAP

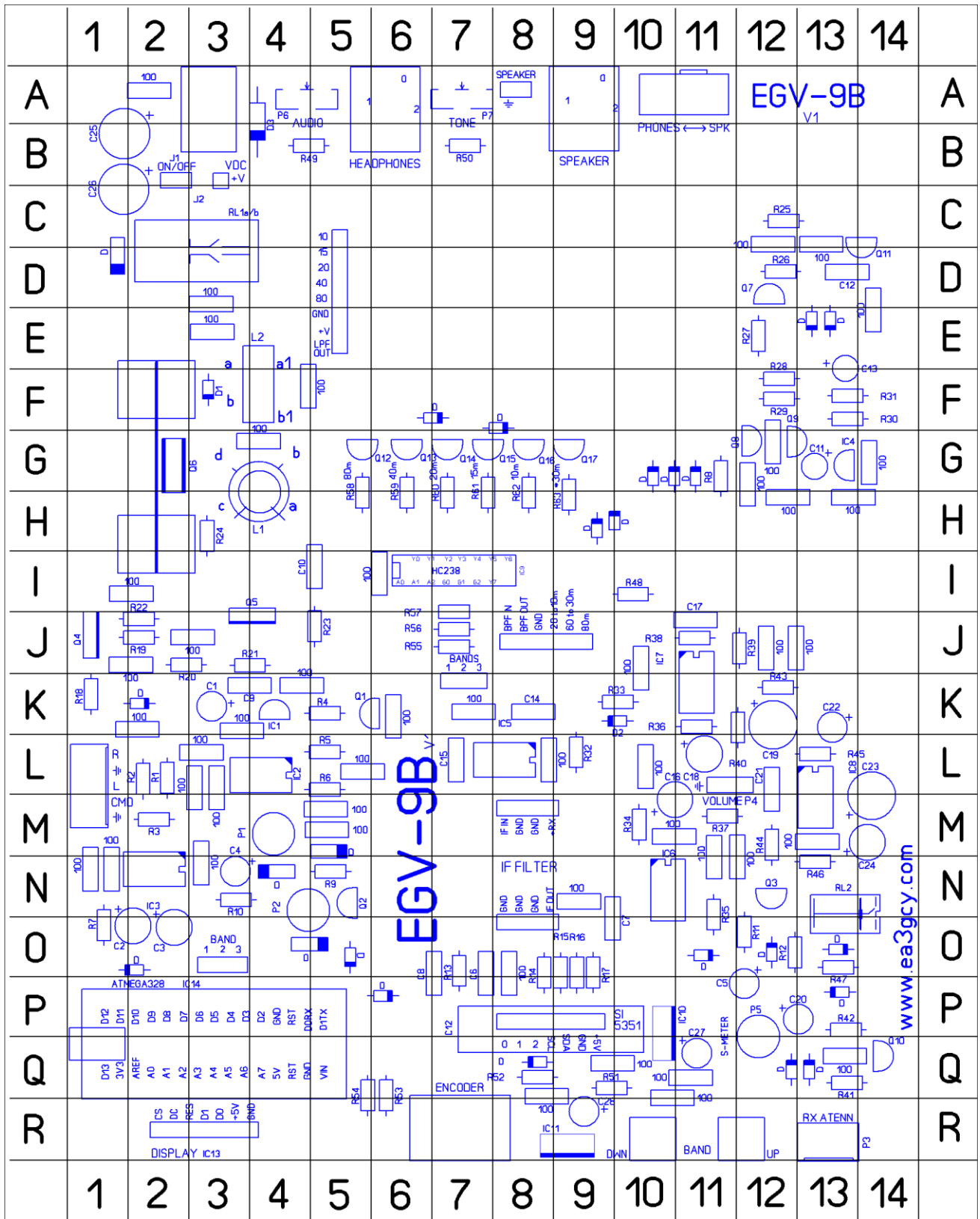

ASSEMBLY

You can use the “individual parts list” or the “value/quantity parts list.” Using the “value/quantity parts list” is the quickest way to mount components since all the circuit board components of the same value or type can be placed one after the other. However, you will need the “individual parts list” to know how each component is identified and its location on the circuit board. Depending on your personal experience, you may prefer the individual parts list and feel more confident using it.

The 252-quadrant component layout map makes it very easy to find the location for all the components. After mounting each component, it can be marked off in the “checked” column.

It is highly recommended that an inventory be taken of all the components to make sure that everything can be located and is ready for assembly. Each builder may have his/her own method of organizing the components. One suggested method is to use a block of Styrofoam packing material and poke the components into it. The components can be sorted by type, value and size (ohms, micro-farads etc.).

All SMD parts soldered at the factory. You don't have to solder anything SMD

RECOMMENDED ASSEMBLY SEQUENCE

⇒ **R**esistors

The resistors are installed first.

Next, mount P1, P2, P5, P6, P7

P3 is the RF attenuator potentiometer. P4 is the volume potentiometer that will be wired later when the board is finished.

Refer to the parts list, and select the first resistor, R1. Bend the leads as close to the component body as possible (otherwise, they will not fit well into the holes), and place them into the appropriate holes according to the component outline printed on the circuit board.

Inserting the resistor leads into the holes, push down on the body of the component so that it rests flat on the board, hold it in place, and then slightly bend the leads to keep the resistor in place. Then turn the board over and solder the leads to the printed circuit trace. Make sure that the resistor body lies flat on the board so that its leads are as short as possible. Place the next resistor in the parts list in the same manner and continue until all the resistors are mounted.

The values which are in decade increments can be easily confused, such as 470, 4K7 and 47K, so be sure to verify the colors before soldering the component in place! If you are in doubt, use a multimeter to check the resistance value.

⇒ **D**iodes

Next mount the diodes, being careful to place them with the correct orientation. There is a dark-colored band on one end of each diode that corresponds to the component outline on the circuit board.

There are 24 x 1N4148 diodes. All diodes printed “D” on PCB are 1N4148; they are normally orange in color with a black band and they have the type “4148” printed on the body. Note that some diodes are mounted in a vertical position.

See the 1N4148 diodes location map below.

























There are three specific type diodes:

D1 is a 47V zener diode.

D2 is 6V2 zener diode

D3 is a BY255 diode.

1N4148 diodes location map:

	1	2	3	4	5	6	7	8	9	10	11	12	13	14	
A															A
B															B
C															C
D															D
E															E
F															F
G															G
H															H
I															I
J															J
K															K
L															L
M															M
N															N
O															O
P															P
Q															Q
R															R
	1	2	3	4	5	6	7	8	9	10	11	12	13	14	

⇒ Capacitors

There are ceramic and electrolytic capacitors. They all have their value printed on the body. Refer to the “identified” column in the parts list.

When you mount them, make sure to leave the leads as short as possible.

- **There are 47 x 100n capacitors. All printed “100” on PCB.** See 100n capacitors location map below.
- C11 and C13 they are electrolytic **miniature** capacitors, so that its height does not touch the filter plug-in board.

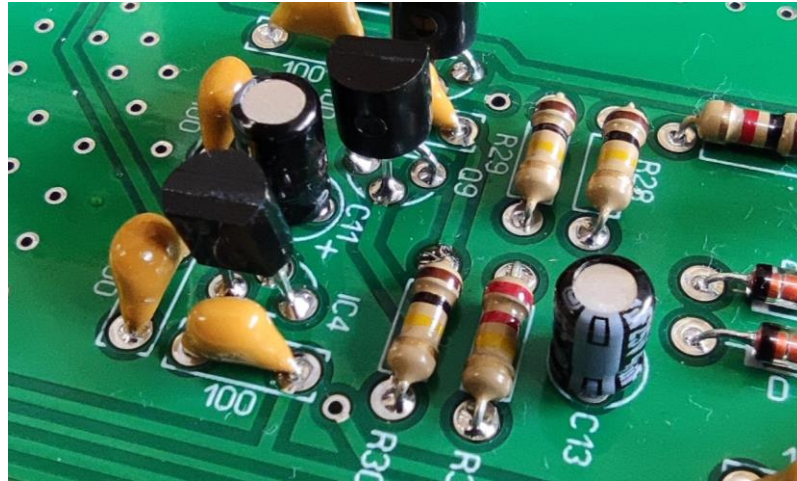

The values which are in decade increments can be easily confused, such as 22p(22), 220p(221) and 10n(103) or 100n(104), so be sure to verify the numbers of their value before soldering them in place!

The electrolytic capacitors must be placed with the correct orientation: the LONG LEAD goes in the hole labeled “+” and the SHORT LEAD is “-”, indicated by a band containing “-” signs on the side of the capacitor.

100n capacitors location map:

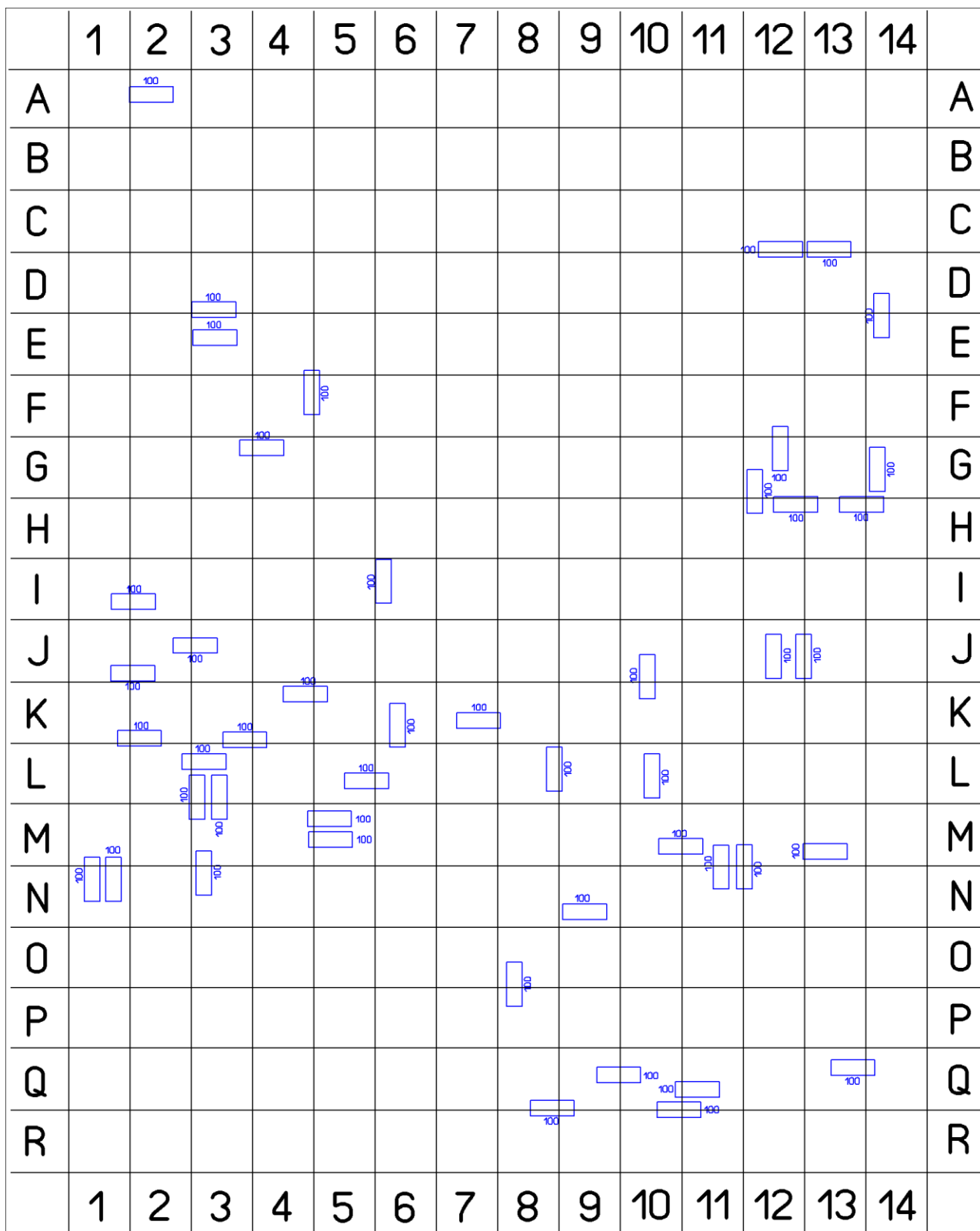

⇒ Pin headers and jumpers

- Place and solder the 5-pin polarized header corresponding to the R, L paddles, CMD switch and GND.
- Place and solder the 2 male pin "J1" ON/OFF.
- Place and solder the two "BAND" 3 male pins strip.
- Place and solder the P4 "VOLUME" 3 male pins strip.
- Place and solder the "SPEAKER" 2 male pins strip.
- Place and solder the **6 female pin strip** for LPF/BPF PCB plug-in.
- Place and solder the **8 female pin strip** for LPF/BPF PCB plug-in.
- Place and solder **2 x female 15 pin** strip for the ATMEGA328P module (Arduino UNO compatible).

Turn the board over and use one hand to insert and hold the header in place, using a "jumper" placed on the header while you solder the pins to avoid burning your fingers. Use your other hand to hold the soldering iron and move the board towards the solder to solder the headers in place. If you have someone available to help you, it will be much easier!

Place jumper on "**J1**" if you do not use an ON/OFF switch.

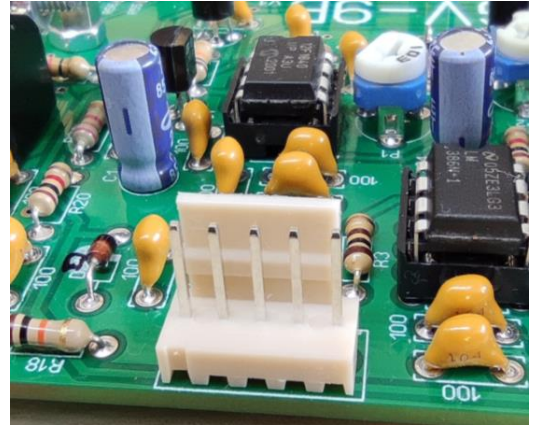
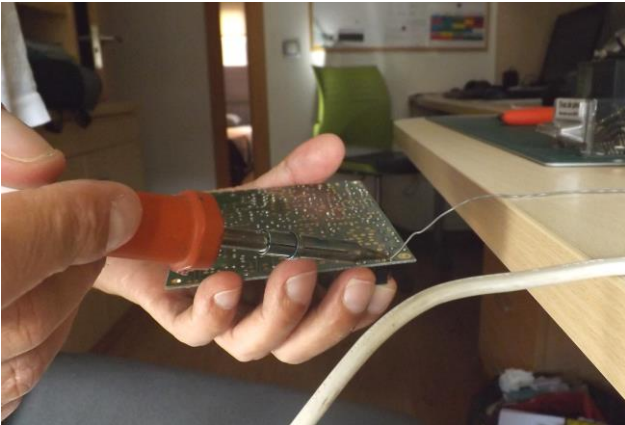

⇒ Transistors

All of the transistors have their type printed on the component body. Place them according to the corresponding component outline printed on the circuit board.

Be very careful not to confuse the types. Although their body is the same but they are different transistors. Use a suitable magnifying glass to read the marked references printed on them.

Q4 BD140

Q4 transistor BD140 has to be placed with its face facing away from the board (see image).

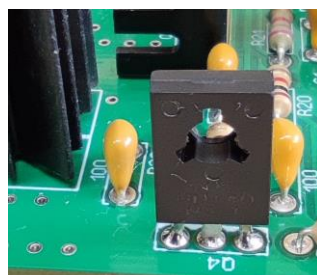

Prepare Q5 and Q6, but do not place them yet. It is better to do it after placing L1 and L2.

Q5 BD135

Mount Q5 onto the heatsink as shown in the image.

Use a mica insulator sheet that you will find in the kit and trim it 1-2mm every side so that it seats well within the heatsink.

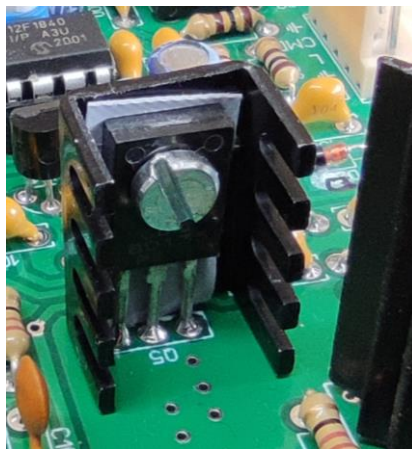
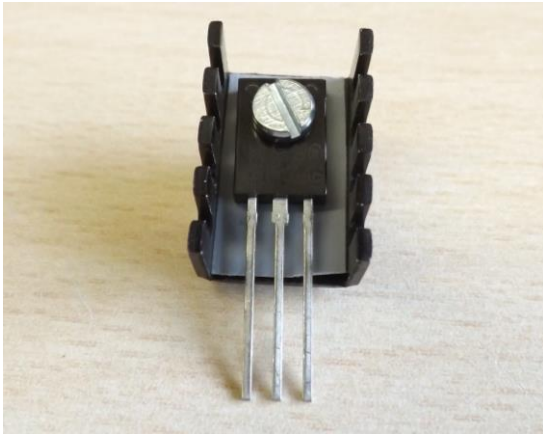

Q6 2SC1969

Mount Q6 (TX power amplifier) onto the heatsink as shown in the image. This transistor is placed with a mica insulator sheet and also a heatsink insulator bushing that insulates the screw from the transistor body.

This is an important task; it should be done exactly as shown in the images.

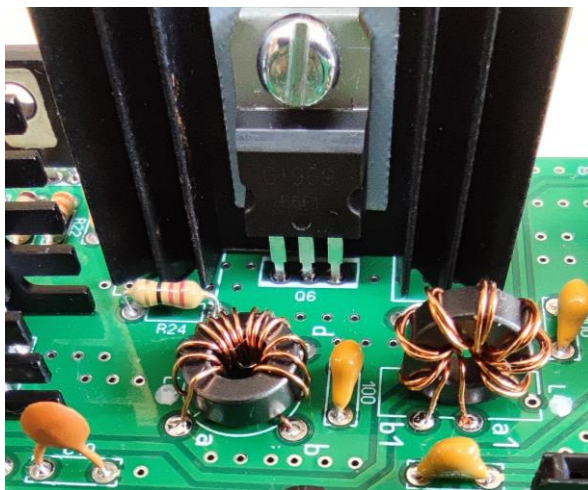
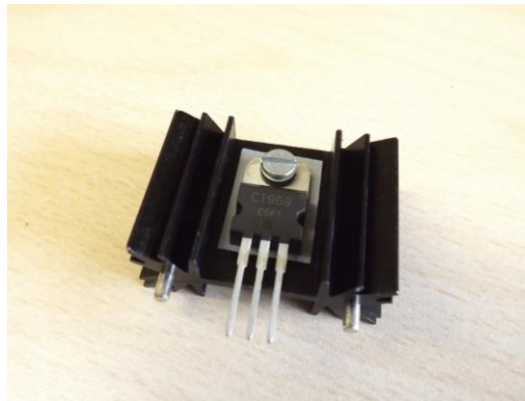
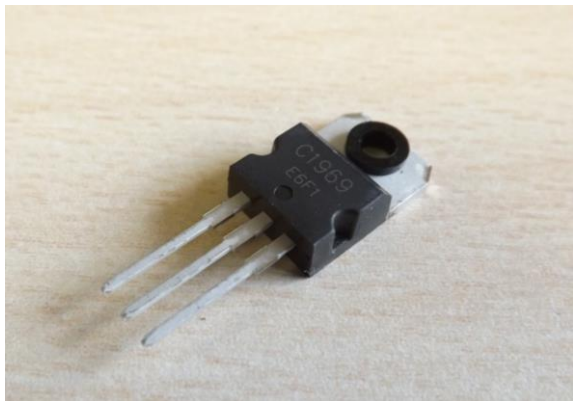

If you plan to work at maximum power and for long periods of time (at base station) it may be advisable to increase the cooling surface. You can add some system to increase the temperature dissipation, for example by an auxiliary metal surface, a mini-fan or other similar system.



You can also screw the Q6 to the base of the metal case through the 6mm hole. In that case place the Q6 under PCB and the radiator from the kit is not used.

⇒ Integrated Circuits

The component outline for the IC on the circuit board has a “U” shaped notch on one end, indicating the end at which pin 1 of the IC is located. There is a similar notch on one end of the sockets. This should be oriented over the “U” notch outline on the circuit board. Finally, pin 1 of the IC is marked with a small dimple or dot; this end of the IC should be oriented towards the notch in the IC socket or the “U” on the component outline.

Mount the sockets for IC2, IC3, IC5, IC6, IC7, IC8, IC9 in the locations printed on the circuit board. Make sure that the sockets lie flat against the circuit board. Next, insert IC2, IC3, IC5, IC6, IC7, IC8, IC9 into their respective sockets.

Install IC1, IC4, IC10 and IC11. These are regulator integrated circuits.

IMPORTANT: Make sure that the IC's are fully inserted into their sockets. A poor contact between the socket and IC can cause malfunction of the kit.

⇒ Relays

Install RL1 and RL2 relays. They can only be placed in one position.

Make sure that the body of the relay lies flat against the circuit board.

L1 Toroid Transformer

L1 is an impedance matching transformer. An FT37-43 (black toroid 9.5mm/0.375in outer diameter) is used. It has a 10-turn primary and a 3-turn secondary.

- Take 16-17cm (7.5") of 0.5mm diameter enameled wire and wind ten (10) turns on a black FT37-43 toroidal core. Spread the turns evenly around the entire toroid and wind them tightly so that they follow the contour of the toroid and are as tight against the toroid as possible. The turns should be evenly distributed around the circumference of the toroid. Leave pigtailed of 10-20mm (0.70").
- Now take about 8 cm (3.5") of 0.5mm diameter enameled wire and wind three (3) turns on the other side of the toroid, spacing the turns over the previous winding. Leave pigtailed of 10-20mm (0.70").
- Before inserting them on the circuit board, use a knife or sandpaper to scrape off the enamel from the pigtailed of the windings. Solder them in place.
- The 3-turn winding (c-d) faces towards the output transistor Q6.

Counting the turns: Count one turn for every pass of the wire through the center of the toroid.

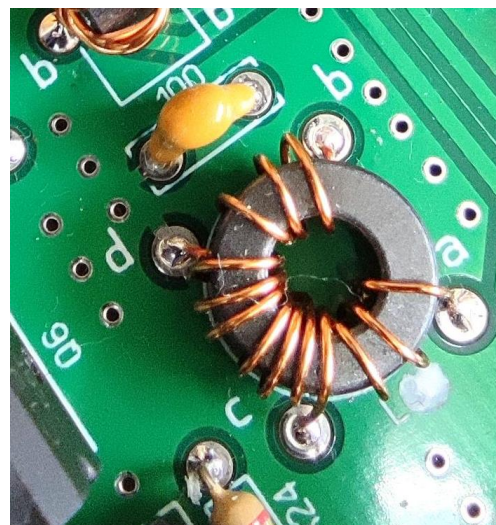
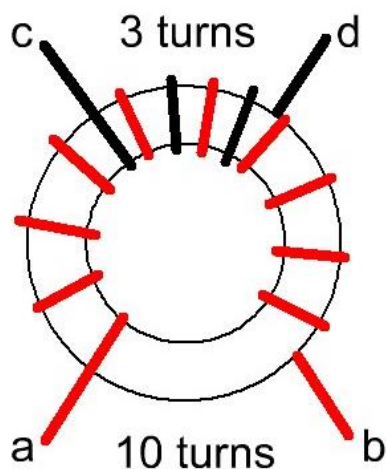

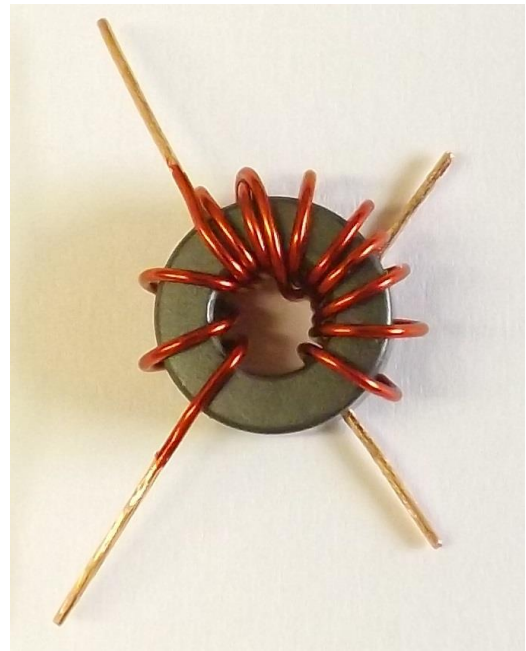
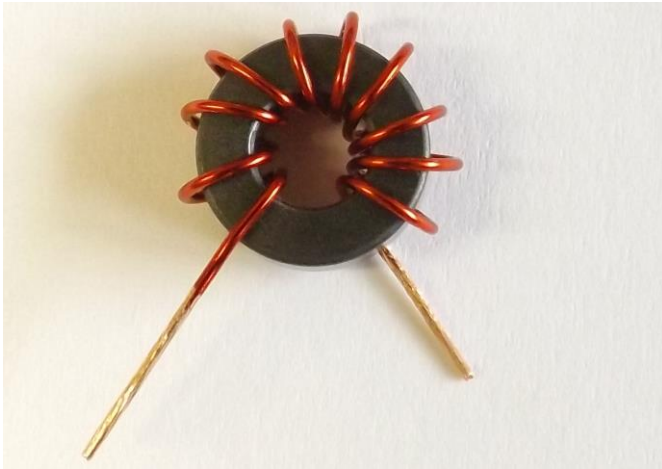

IMPORTANT: Wind the toroid exactly as shown in the images. You must pay attention to number of turns as well as to the direction of the winding.

⇒ L2 Toroid transformer

L2 is an impedance matching transformer with a bifilar winding. An FT37-43 (black toroid with 9.5mm/0.375in outer diameter) is used. It has 8 + 8 turns.

- Cut a 30-31cm (12") long piece of 0.5mm diameter enameled wire.
- Bend the wire in half.
- Twist it so that there are two twists per cm.



16cm (32cm bent in half)

- Before beginning to wind, leave 15-20mm of wire, measured from the end of the wires to the outer edge of the toroid. Now wind eight (8) turns on the toroid. Remember: Count one turn for each pass of the wire through the center of the toroid.
- Spread the turns evenly around the toroid.



- Cut the ends and separate the two windings.
- Use a sharp knife to scrape the enamel off the ends that will be soldered. The ends of the coils that we have made need to be prepared in this manner before soldering them into the board.
- Using a multimeter in its ohm or continuity function, locate and mark the ends, identifying them as "a" - "a1" and "b" - "b1".
- Mount the toroid into the appropriate holes as marked on the circuit board.

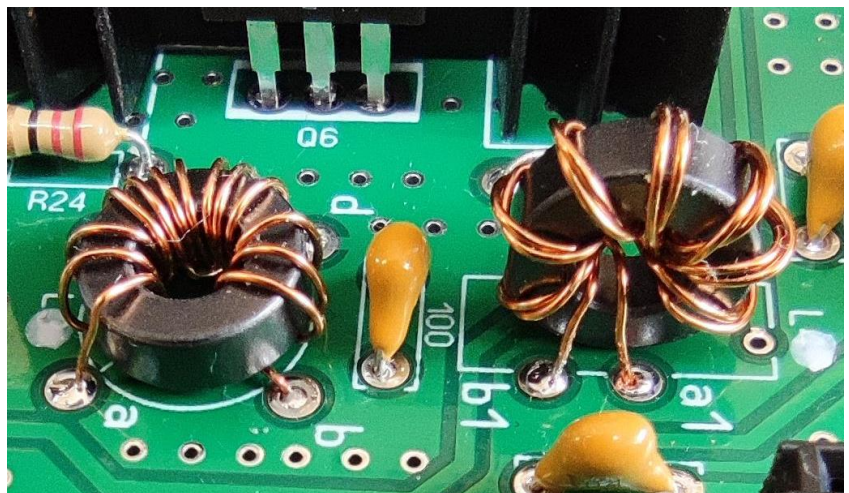
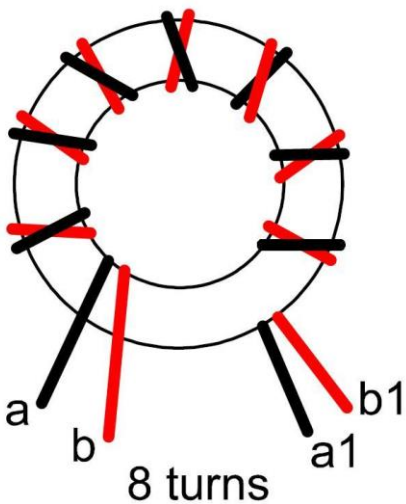

Note: For greater clarity, the drawing shows one black wire and one red wire. In reality, both wires are of the same color. You can mark the "a" -"a1" with a marker pen.

⇒ **R**otary **E**NCODER, **P3 RX** attenuator potentiometer, **P4** volume potentiometer, **UP-DOWN** band switches and external connections **J**acks, (antenna, speaker, headphones, power supply) and the speaker-headphone **S**witch

Now mount and solder the Rotary Encoder, the P3 RX attenuator potentiometer (marked B1K) and UP and DOWN BAND switches on PCB in their respective locations.

Wire the volume potentiometer P4 (marked B10K) so that you can install it in the chosen box. The P4 potentiometer incorporates a switch to use it as ON/OFF (wire it to J1). Place and solder the antenna and power supply jacks, headphones and speaker jacks, and the speaker-headphones switch.

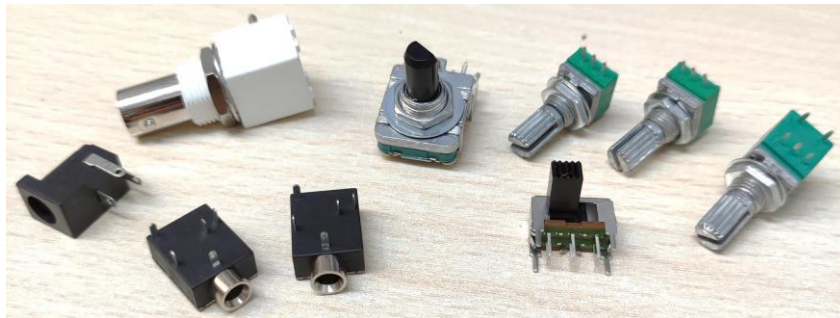

⇒ **IF** Crystal filter plug-in module

The IF crystal filter is mounted on a plug-in board. This allows for easy experimentation. Also in the future you can exchange other filter modules with different characteristics.

The PCB and components are in a separate bag. Place and solder the parts on board:

- QFL is BC547
- RFL is 1K5 resistor (brown, green, red)
- CFL1, CFL2 and CFL3 are 390p capacitors (marked 390 or 391)
- XFL1, XFL2 and XFL3 are 4.915MHz crystals.

The spacers to screw the board are 10mm. See the images.

Extra-long strips of pins are used. Before soldering you should pay close attention to how tall the pins should be to accommodate the position of the plug-in board.

- First put the board in place no solder pins.
- Insert the pins from the top side of the PCB and push them all the way into the sockets.
- Now you can solder on the top face on PCB. Use a fine tip soldering iron very carefully and solder below the plastic strip.

See the following images:

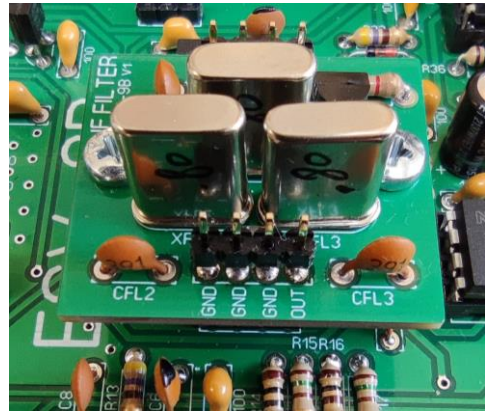
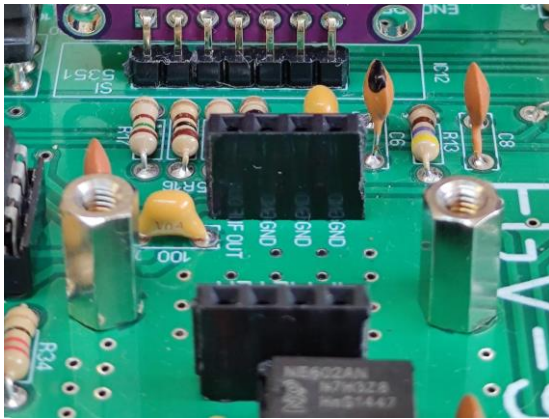

⇒ IC12 SI5351

The IC12 is a module that incorporates the SI-5351 frequency generator

Solder the elbow 7-pin strip and solder the module onto the board.

Make sure that the module is vertically with the board as shown in the images.

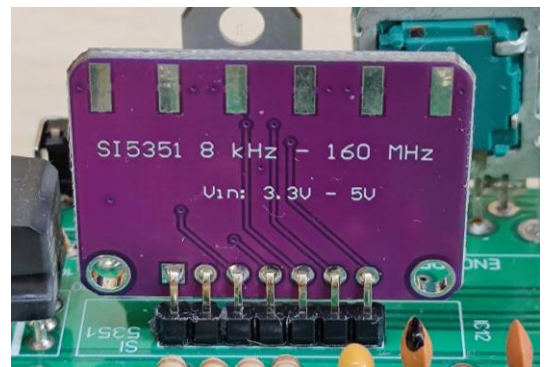

⇒ IC13 OLED 1.3" display

This is the display for the EGV-9B. It may be best not to place it to the end.

Before placing it, you must think and be sure how to install the EGV-9B in your enclosure.

The OLED display use a strip of 7 pins at right angles to solder the module onto the board.

When solder, you can adjust the distance a little to match the front panel of the enclosure (See the EGV-9B BOX manual).

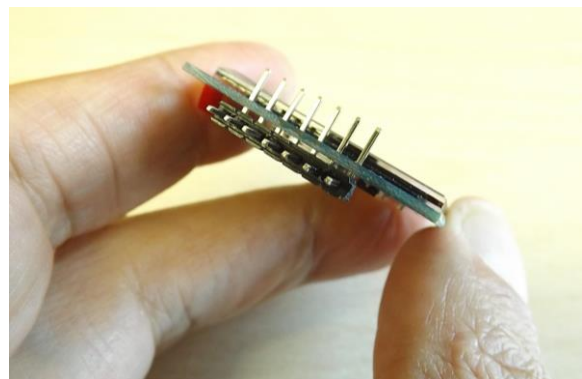
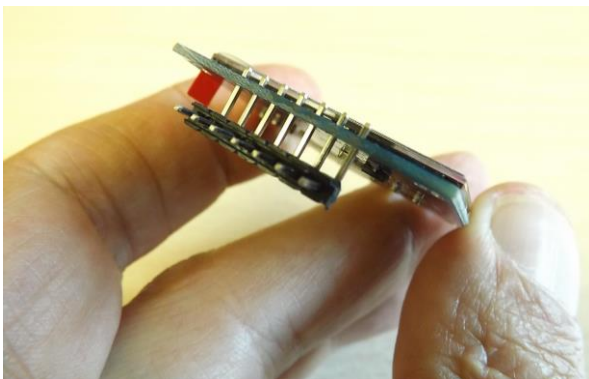

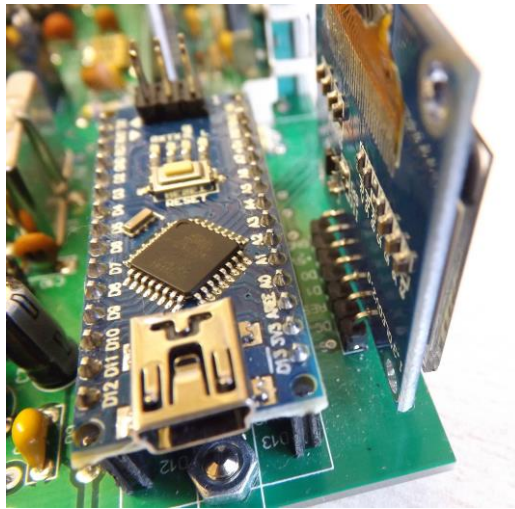

⇒ **IC14** ATMEGA328P module (Arduino NANO compatible)

Install the two 15-pin female strips on EGV-3B board to ATMEGA328P or Arduino NANO module as shown in the image.

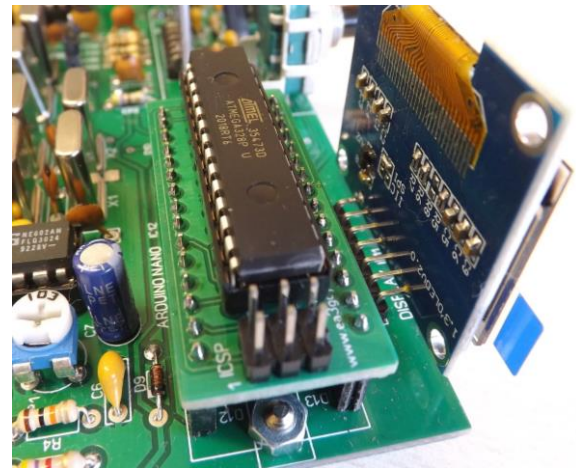
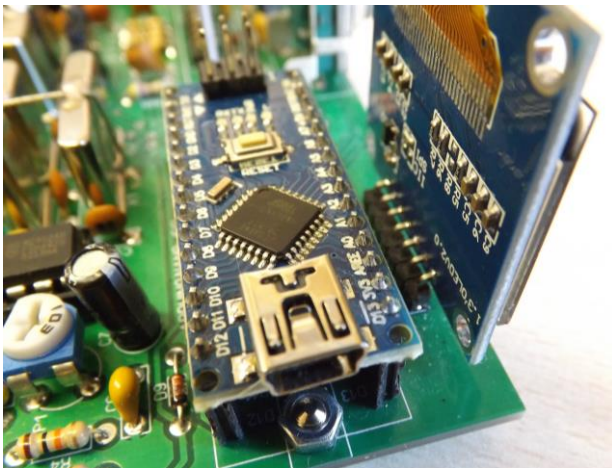

WIRING AND CONNECTIONS

- The EGV-9B requires wiring of the paddles, CMD push button, RX pass-band potentiometer.
- The EGV-9B requires wiring “VOLUME” and “V-TUNE” (Band tune) potentiometers.
- The EGV-9B circuit board incorporates the power, antenna, headphone, and external speaker and headphone jacks and “speaker/headphones” switch.
- Optionally, you can connect an ON/OFF switch instead of jumper J1.

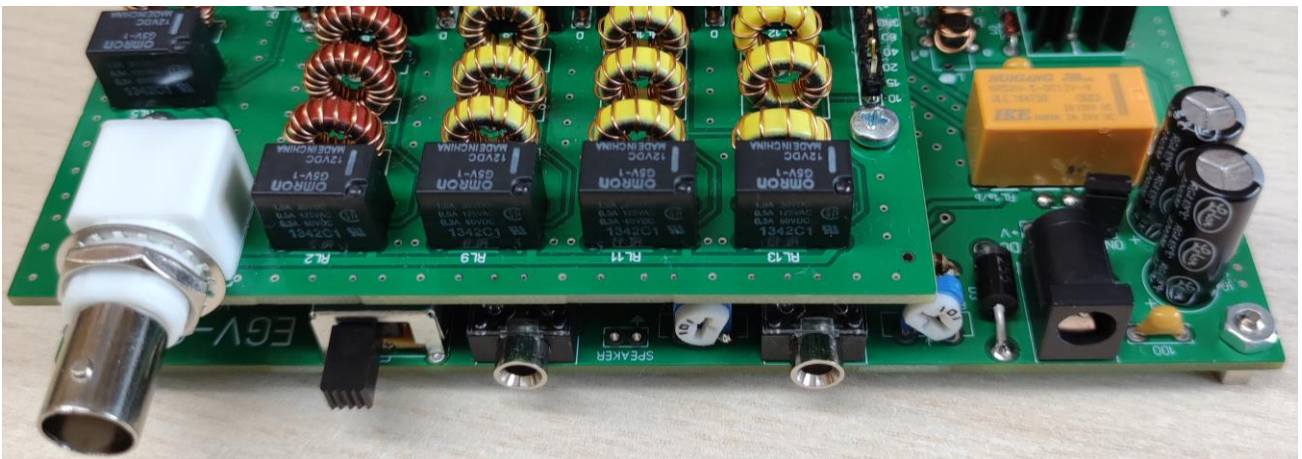

⇒ Wire the LPF/BPF “BAND” connections

So that the processor can switch the low-pass filters you need to wire the terminals 1-2-3 of the “BAND” connections (next to the processor) to the “BAND” in front of Q12 – Q17. See the pictures.



⇒ Wire paddle connector and “CMD” push-button.

On the EGV-9B PCB

The paddles and the "CMD" command push-button connector has 5 pins:

“R” (right paddle), “GND”, “L” (left paddle), “CMD” (command push-button) and “GND”.

Note: this connector has two “GND” pins. *The two are the same.*

On the small PCB for panel connection

The small PCB incorporates the Jack for the paddles and the “CMD” push button.

See the image.

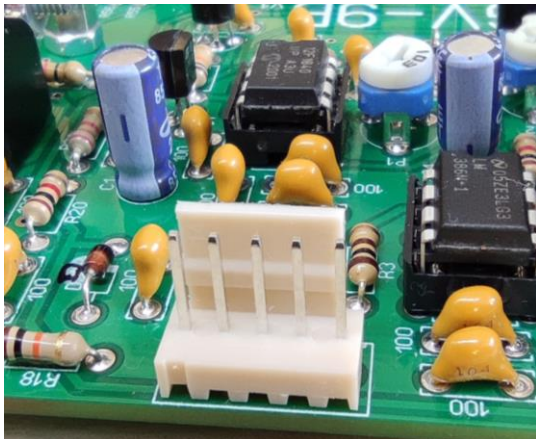

You have to wire the connections "R", "GND", "L" and "CMD"

Note: You can use a different connectors system. You can use another Jack socket type and another push-button.

To understand how the **KB2 keyer works, download the manual from www.qrphamradiokits.com**

⇒ Wire “Volume” and “V-TUNE” (band tune) potentiometers.

Wire the Volume and Band Tuning potentiometers from the PCB to the panel where the potentiometers are housed. It is recommended that you use cables of different colors and that you twist them together (see images). The volume potentiometer incorporates a switch for ON/OFF, wire this switch to jumper J1 (ON/OFF).

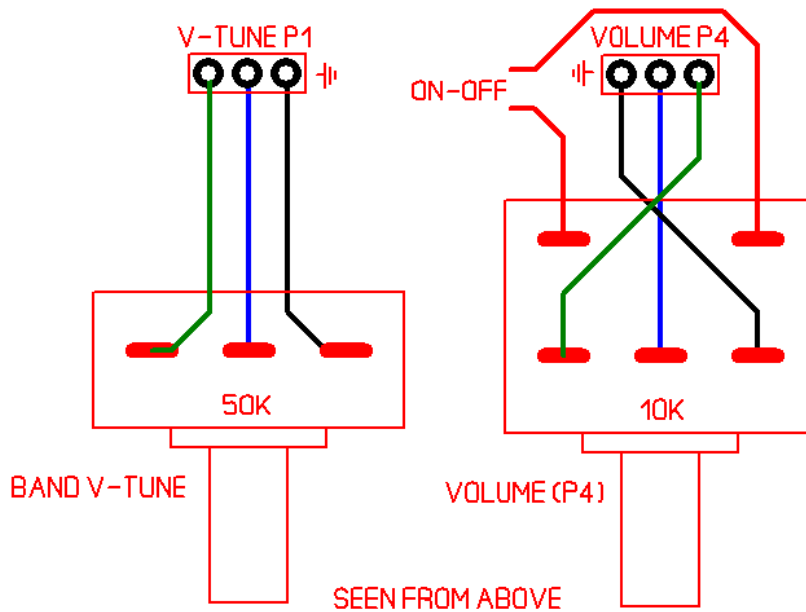
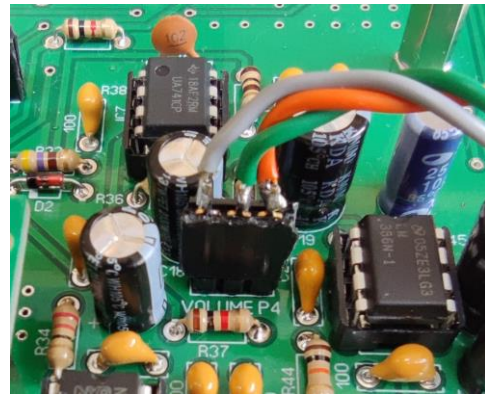
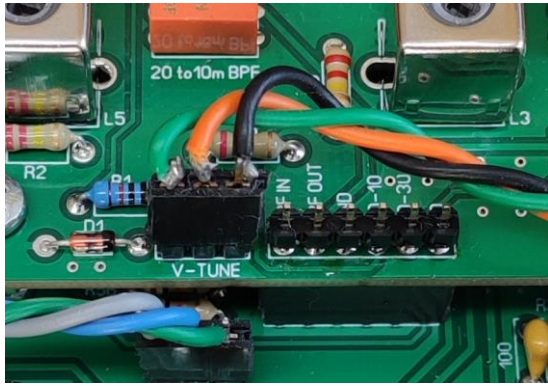

⇒ **EGV-9B enclosure.**

It is highly recommended that suits a metal box for all items that are installed on the board. If you use a plastic box, then make RFI shield with conductive paint or conductive tape (aluminum or copper may be suitable). There is a custom enclosure for the EGV-9B in www.qrphamradiokits.com

Download the EGV-9B-BOX assembly manual from: www.qrphamradiokits.com/manuals

The EGV-9B is protected against possible polarity reversal faults by means of diode D3

If your power supply is short-circuit protected or is equipped with a fuse at the output, perfect; if not, build or purchase a cable with a built-in series 2.5 or 3A fuse.

If you make a mistake with the polarity, then the fuse will blow.

SETTINGS AND TESTS

⇒ **F**irst checks

- Adjust all adjustable resistors (P1, P2, P5) and P4 (volume potentiometer) to mid-position.
 - Adjust P3 (RX potentiometer) to maximum position (clockwise).
 - Plug a speaker into the "SPEAKER" jack or headphones into the "PHONES" jack.
- IMPORTANT: Use a good quality speaker unit. A bad speaker will spoil the quality of the reception.
- Apply power (remember **J1** jumper plugged).
 - The screen should light up and show the main menu. See "EGV-9B Settings-User manual".
 - Turn the volume to maximum; you should hear a light background noise.

If everything is okay, you may continue.

If something is not right, you will need to examine it.

⇒ **S**ettings on firmware menu.

Please, download the "EGV-9B Settings Manual" from the website: www.qrphamradiokits.com

IMPORTANT:

"CALIBRATE XTAL" and "BFO" settings are essential to suit your assembly.

The "CALIBRATE XTAL" adjust is essential to adapt the SI5351 module to your assembly. This is the first thing you have to adjust, before receiver.

An incorrect setting can cause the EGV-9B to not receive.

The "BFO" frequency adjust is used to suit the tolerances of the IF crystal filter for each setup. This adjustment will affect the quality of reception.

⇒ Adjustment of the band-pass filters shielded coils.

For these setting you will need an “alignment” tool suitable for this type of coils; if you use a screwdriver, you risk breaking the core of the coil.

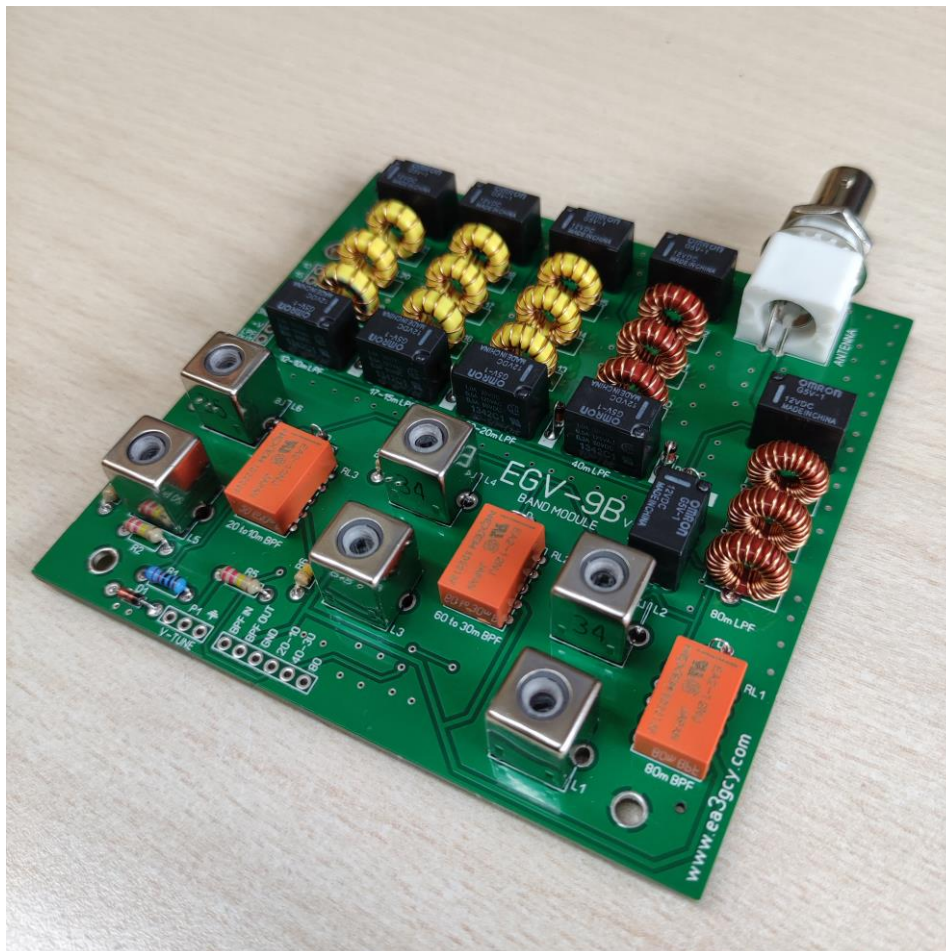

L1 and L2 - 80m band-pass filter.

L1 and L2 adjust the band-pass for 80m, this setting is fixed and is not affected by the “band” tuning potentiometer (P1). With an antenna connected to the transceiver tune any frequency in the 80m and adjust L1 and L2 until you get the maximum signal level.

L3 and L4, 60-40-30m band-pass filter.

Set the potentiometer P1 (50K) “RX Tune” from LPF/BPF plug-in module 20-25% of the start of its route. Tune any frequency in the 40m. Alternately adjust L3 and L4 until you get the maximum signal level from antenna.

For 60m band, adjust P1 potentiometer on the beginning of his turn.

For 30m band adjust P1 potentiometer (clockwise) from about halfway until you get the highest signal level.

Note: Adjust L3 and L4 for 40m do not re-adjust L3 and L4 on the other bands.

L5 and L6, 20-17-15-12-10m band-pass filter.

Tune to any frequency in the 20m, adjust P1 "RX Tune" from LPF/BPF plug-in module on the beginning of his turn (fully rotated anti-clockwise). Alternately adjust L5 and L6 until you get the maximum signal level from antenna. You will find the other bands by turning the potentiometer clockwise.

Note: We recommend that you adjust L5 and L6 for 20m do not re-adjust L5 and L6 on the other bands. You will notice that on the higher bands the adjustment of L5 and L6 can be tweaked slightly. You could do a "compromise" re-adjustment, but this will affect the lower bands. This is inherent in the architecture of this receiver.

If you have access to an RF signal generator, begin injecting a signal of about 5-10uV within the frequency coverage of the receiver and tune it in. Reduce the level of the RF signal generator to the minimum that is still audible with a loudspeaker or headphones, and alternately adjust the coils until obtaining the maximum reception level.

L1 to L6 are adjusted to RX. There is no any coil to adjust in TX.

Remember: All TX tests must be done with a 50 ohm load connected to the transceiver output.

⇒ **T**ransmitter.

Connect a power meter with a 50 ohm load to the antenna jack.

Connect a CW key to terminals "L", "R" and "GND" and transmit. The power meter will display the power output level. **You can expect from 2,5 to 7W beetwen 3 to 30MHz (about 12-14V supply).**

⇒ **A**ddjustment of **P1** CW Sidetone monitor level and **P6** and **P7** Headphone levels

Plug a speaker on socket jack. Toggle the speaker-headphones switch to Speaker

Adjust the level you like best.

Normally **P1** will be adjusted to mid-position or less.

Plug in headphones and toggle the switch from Speaker to Headphones. Adjust the P6 to get the receive audio level you like best. Adjust the P7 to get the Sidetone level you like best.

⇒ **A**ddjustment of **P2** TX to RX decay delay.

Adjust to your liking, based on your CW speed

⇒ **A**ddjustment of **P5** S-Meter level.

You can use another receiver to compare.

Tune in a stable signal and adjust P5 until the display shows the proper signal level.

Normally P5 will be adjusted to its three quarters.

Note: The displayed signal level is for guidance only. They are not precise levels. It is not a calibrated circuit.

ANNEXES AND TIPS

⇒ **KB-2** Electronic KEYER.

Please, download the “EGV-9B KB2 User Manual” from the website:
www.qrphamradiokits.com

⇒ **I**ncreasing the AGC decay.

The CAG decay time can be increased by changing the values of C13 and R31.
Try increase R31 to 1M. This modification will depend on your listening habits.
If you are satisfied with the current values, do not make the modification.

⇒ **RX ATT** Using the fader control.

When very strong signals are received, the AGC may receive strong pulses before reacting (the first dot or dash). When the band is open and the propagation is high, **it is highly recommended to use the Attenuator control potentiometer (RX ATT) to reduce the receiver sensitivity** enough for the AGC to work easily and the signals to be heard comfortably. **Then you can increase the volume control.**

When broadcast signals near the amateur bands are strong, you should also use the RX ATT control to minimize possible interference.

⇒ **D**ecreased drop delay TX to RX.

First you can decrease the value of C4 and then you can also decrease C5.
There should be a minimum delay to avoid noise bumps when returning to RX.

⇒ **E**liminating "plops" in RX-TX and TX-RX switching.

If you notice “plops” in transmit to receive switching, you can try to jumper the pads **J2** above the RL1a/b relay. This can eliminate or minimize "plops".

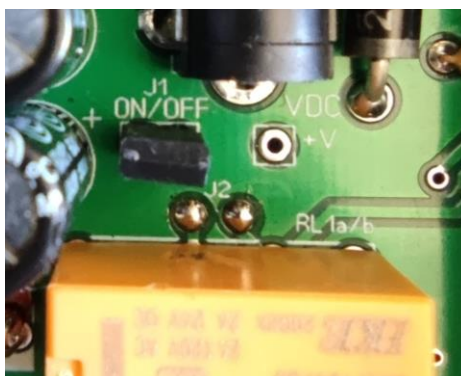

⇒ **D**ecreasing or increasing audio gain.

You can increase the gain of the audio by changing the R45 resistor to 1ohm or by replacing it with a jumper. By increasing the audio gain, you will also slightly increase the internal noise of the receiver and distortion. You can decrease the audio gain by increasing the value of R45, try 1K, this is especially useful if you often use headphones.

⇒ **I**F Filter Bandwidth.

You can increase or decrease the IF filter bandwidth by decreasing (wider) or increasing (narrower) the value of capacitors CFL1, CFL2, and CFL3.

You can try upscaling to 470p or downscaling to 270p or lower.

⇒ **R**X “Birdies”.

Some internal signals, "little birds" are heard at some points on the dial. The “birdies” are internally generated signals produced by heterodyning with the local oscillator and/or in the CW “BFO” demodulator. You can also hear spurious signals coming directly from the SI5351 frequency synthesizer or ATMEG328P processor or from beats in between.

Most of the “birdies” heard on the *EGV-9B* are weak (S-0 level) and don't bother reception much. However, there are some very strong ones that can disable the reception of the signal from the station that is on that exact frequency.

This is inherent in the *EGV-9B* receiver architecture and cannot be avoided.

⇒ **T**X Output Power.

The output power in TX changes according to the selected band. The *EGV-9B* can work in a wide power supply range (from 10 to 14V). The supply voltage greatly influences the output power. In some bands the power exceeds 5W (normalized power for QRP), so you can lower the power and you will get less power. To decrease power, the transmission circuitry of the *EGV-9B* can be modified. However, to carry out modifications, you must have considerable experience in this type of circuit. If you make changes, you are responsible for the results.

⇒ **E**xternal automatic Keyer.

If you have an external automatic keyer, then you can remove IC2 (KB-2) and activate transistor Q1 directly. If the external keyer generates side-tone, you can inject it directly into the IC3.

LIMITED WARRANTY

Please read carefully BEFORE building your kit

All electronic components and hardware supplied with the kit are under warranty in case of any manufacturing defect for the period of one year after purchase. The warranty does not include the transmitter final amplifier transistor.

The original purchaser has the option of examining the kit and manual for 10 days. If, within this period, the buyer decides not to build the kit, he/she may return the entire unassembled kit at their own expense for the shipping expenses. The shipping expenses and sales commissions (i.e. bank, EBay, and PayPal commissions) included in the purchase price will not be returned.

Please, BEFORE returning a product, request instructions by email at: ea3gcy@gmail.com

Javier Solans, EA3GKY, warrants this device to function according to the specifications, provided that it is assembled and adjusted as described in this documentation, and used correctly according to all provided instructions.

It is your responsibility to follow all the instructions in the manual, to identify all the components correctly, and to use good

workmanship and proper tools and instruments in the construction and adjustment of this kit.

REMEMBER: This kit will not work as a commercially manufactured product; however, it can often give similar results. Do not expect great performance, BUT YOU ARE SURE TO HAVE LOTS OF FUN!

If you believe that there is a missing kit component, please do a thorough inventory of all parts using the parts list in the manual. Check all bags, envelopes and boxes carefully. If needed, you may email me and I will replace any component that you are missing. Even if you can find the exact part locally, please let me know so that we are aware of the problem to help other customers.

I can also supply any part that you have lost, damaged or broken accidentally.

If you find any errors in this manual or would like to make a comment, please do not hesitate to contact me at ea3gcy@gmail.com

THANK YOU for building the **EGV-9B** Transceiver kit. Enjoy QRP!
73 Javier Solans, EA3GKY

SCHEMATICS

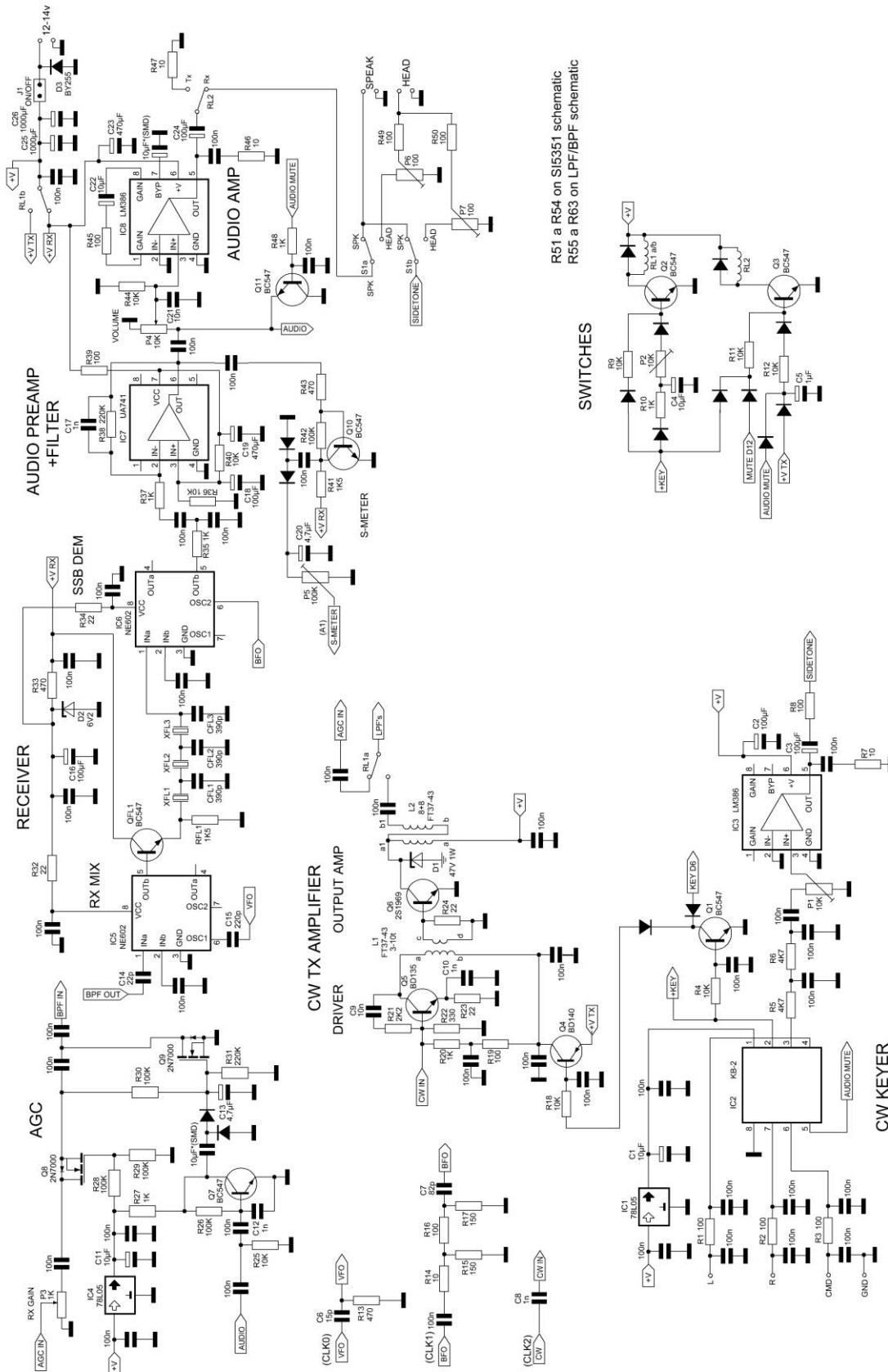

R51 a R54 on S15351 schematic
R55 a R63 on LPF/BPF schematic

SWITCHES

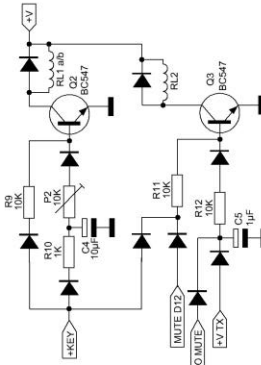

EGV-9B v1 (Main board)

All unmarked diodes are 1N4148

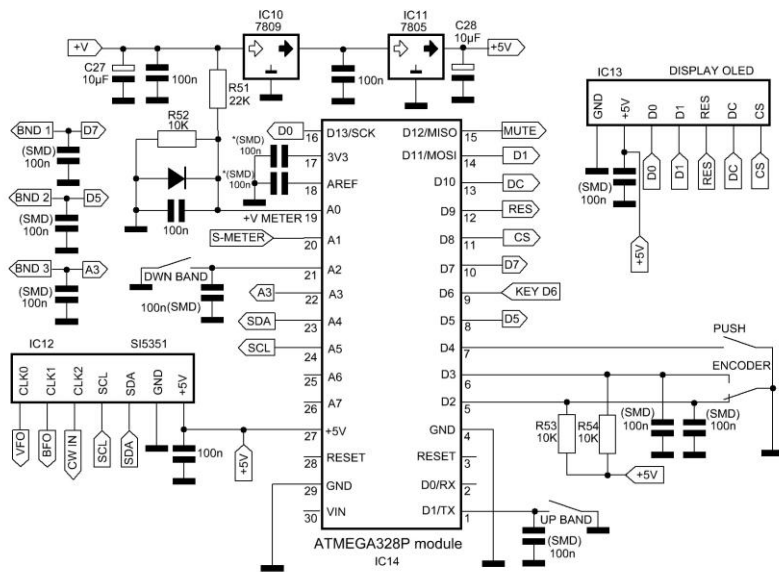

SI5351 EGV-9B v1 All SMD capacitors on PCB bottom layer