

# EGV-9B\_BPFLPF

# v1

## BPF/LPF module for EGV-9B

Last update March 01, 2023

[ea3gcy@gmail.com](mailto:ea3gcy@gmail.com)

Latest updates and news in: [www.ea3gcy.com](http://www.ea3gcy.com)

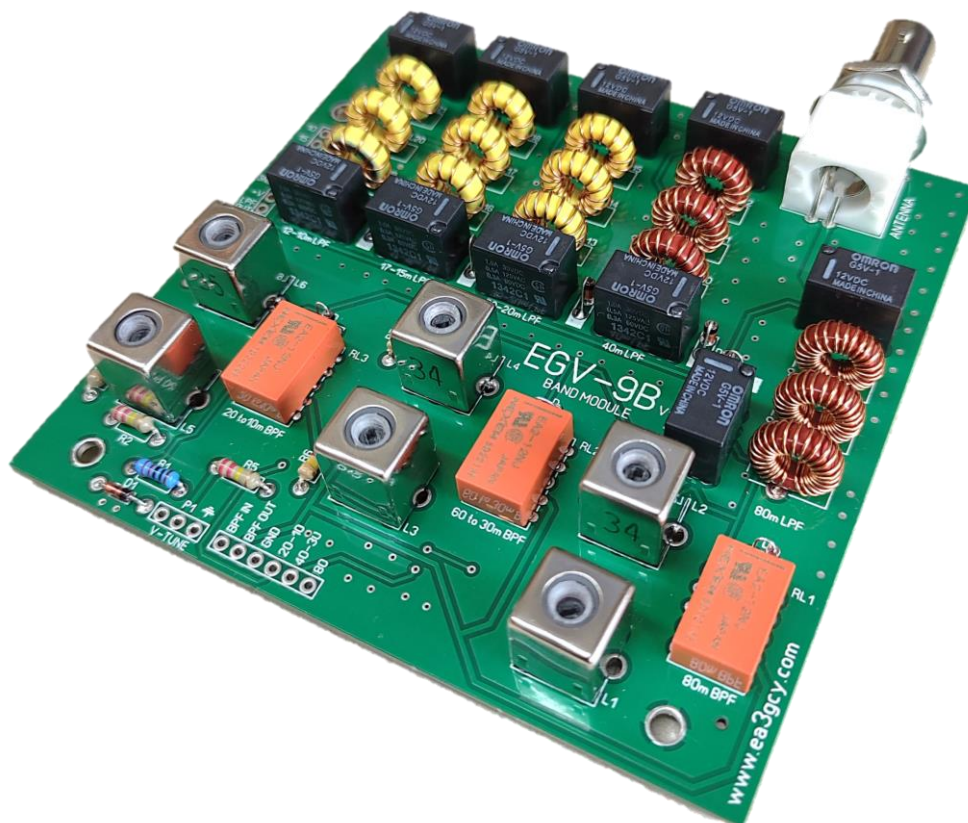

Thank you for building the **EGV-9B\_BPFLPF v1** module

Have fun assembling it and enjoy QRP! 73 Javier Solans, ea3gcy

# INTRODUCTION

## EGV-9B\_BPFLPF

The *EGV-9B\_BPFLPF* is the 3 to 30MHz filter plug-in module for the *EGV-9B* 9-band CW transceiver. This module incorporates 5 7-pole low-pass filters and two variable band-pass filters and one band-pass filter. All the filters are switched by means of relays to avoid their interactions.

**Note: good experience on radio assembly is required. It shouldn't be your first transceiver to build.**

*All SMD parts soldered at the factory. You don't have to solder anything SMD*

# SPECIFICATIONS

## ***RX BAND-PASS FILTER:***

**Power requirements:** 12 – 14VDC

**Antenna impedance:** 50 ohms nominal.

**Frequency:**

- 1) Fixed filter for 80m
- 2) Variable filter from 60 to 30m
- 3) Variable filter from 20 to 10m

## ***LOW PASS FILTER:***

**Filters:** 80m, 60-40m, 30-20m, 17-15m and 12-10m

**Harmonics output:** -45dBc or better below the fundamental frequency (**excepted 60, 17 and 12m**)

**Other spurious signals:** -50dBc or better below the fundamental frequency.

**60, 17 and 12m bands:** The attenuation of harmonics signals are not so good.

**Switching:** Relays.

**Board dimensions:** 100 x 100 mm.

***PLEASE READ ALL ASSEMBLY INSTRUCTIONS COMPLETELY AT LEAST ONCE BEFORE YOU BEGIN.***

# COMPONENT LIST

Resistors				
Checked	Ref.	Value	Ident./Comment	Located
	R1	220 Ω		Top layer
	R2	220K		Top layer
	R3	220K		Top layer
	R4	220K		Top layer
	R5	220K		Top layer
	R6	220K		Top layer
	R7	220K		Top layer
Potentiometer				
	P1	50K	50K shaft potentiometer 50K 503	Top layer

Capacitors				
Checked	Ref.	Value	Ident./Comment	Located
	C1	470p	SMD capacitor NPO or CG0 100V	Bottom layer
	C2	1200p	SMD capacitor NPO or CG0 100V	Bottom layer
	C3	1200p	SMD capacitor NPO or CG0 100V	Bottom layer
	C4	470p	SMD capacitor NPO or CG0 100V	Bottom layer
	C5	270p	SMD capacitor NPO or CG0 100V	Bottom layer
	C6	680p	SMD capacitor NPO or CG0 100V	Bottom layer
	C7	680p	SMD capacitor NPO or CG0 100V	Bottom layer
	C8	270p	SMD capacitor NPO or CG0 100V	Bottom layer
	C9	180p	SMD capacitor NPO or CG0 100V	Bottom layer
	C10	390p	SMD capacitor NPO or CG0 100V	Bottom layer
	C11	390p	SMD capacitor NPO or CG0 100V	Bottom layer
	C12	180p	SMD capacitor NPO or CG0 100V	Bottom layer
	C13	82p	SMD capacitor NPO or CG0 100V	Bottom layer
	C14	220p	SMD capacitor NPO or CG0 100V	Bottom layer
	C15	220p	SMD capacitor NPO or CG0 100V	Bottom layer
	C16	82p	SMD capacitor NPO or CG0 100V	Bottom layer
	C17	56p	SMD capacitor NPO or CG0 100V	Bottom layer
	C18	150p	SMD capacitor NPO or CG0 100V	Bottom layer
	C19	150p	SMD capacitor NPO or CG0 100V	Bottom layer
	C20	56p	SMD capacitor NPO or CG0 100V	Bottom layer
	C21	100n	SMD capacitor 50V	Bottom layer
	C22	100n	SMD capacitor 50V	Bottom layer
	C23	100n	SMD capacitor 50V	Bottom layer
	C24	100n	SMD capacitor 50V	Bottom layer
	C25	100n	SMD capacitor 50V	Bottom layer
	C26	100n	SMD capacitor 50V	Bottom layer
	C27	100n	SMD capacitor 50V	Bottom layer
	C28	2p7	SMD capacitor 50V	Bottom layer
	C29	4p7	SMD capacitor 50V	Bottom layer
	C30	390p	SMD capacitor 50V	Bottom layer
	C31	390p	SMD capacitor 50V	Bottom layer
	C32	33p	SMD capacitor 50V	Bottom layer
<b>Note: All SMD places allow 0603, 0805, 1206 or 1210 format</b>				

<b>Semiconductors</b>				
Checked	Ref.	Type	Ident./Comment	Located
	Printed "D"	8 x diodes printed D are 1N4148 (vertically mounted)		Top layer
	Printed "DV"	All diodes printed DV are BB201 SMD (bottom layer PCB)		Bottom layer
	D1	10V zener 0.5W	10V	Top layer

<b>Inductors/RF Transformers/Relay</b>				
Checked	Ref.	Value/Type	Ident./Comment	
	L1	5u3H 3334	34 Shielded coil	Top layer
	L2	5u3H 3334	34 Shielded coil	Top layer
	L3	5u3H 3334	34 Shielded coil	Top layer
	L4	5u3H 3334	34 Shielded coil	Top layer
	L5	1u2H 3335	35 Shielded coil	Top layer
	L6	1u2H 3335	35 Shielded coil	
<b>Winding toroids (see text)</b>				<b>Turns (0.4 wire)</b>
	L7	T37-2	Red toroid	25 turns
	L8	T37-2	Red toroid	27 turns
	L9	T37-2	Red toroid	25 turns
	L10	T37-2	Red toroid	18 turns
	L11	T37-2	Red toroid	20 turns
	L12	T37-2	Red toroid	18 turns
	L13	T37-6	Yellow toroid	15 turns
	L14	T37-6	Yellow toroid	16 turns
	L15	T37-6	Yellow toroid	15 turns
	L16	T37-6	Yellow toroid	12 turns
	L17	T37-6	Yellow toroid	14 turns
	L18	T37-6	Yellow toroid	12 turns
	L19	T37-6	Yellow toroid	10 turns
	L20	T37-6	Yellow toroid	11 turns
	L21	T37-6	Yellow toroid	10 turns
<b>Relays</b>				
	RL1 to RL3	EA2-12NJ	EA2- 12NJ (NEC or KEMET)	--
	RL4 to RL13	G5V-1 12V	Omron G5V-1 12V	--

<b>Hardware</b>			
Checked	Qty/Ref.	Type/Comment	Located
	1 BNC socket	BNC socket	Top layer
	8 pins strip	8 pins extra long strip (LPF switching)	Top layer
	6 pins strip	6 pins extra long strip (BPF switching)	Top layer
	3 pins strip	3 pins strip "V-TUNE"	Top layer
	4 10mm spacers	4 pcs 10mm metal spacers	Top layer
	4 M3 nuts	4 pcs. M3 nuts	Top layer
	4 M3x10	4 pcs. M3 x 10mm screws	Bottom layer
	4 M3x4	4 pcs. M3 x 4 or 5mm screws	Top layer
	400 cm	400 cm enamelled wire 0,4mm	--

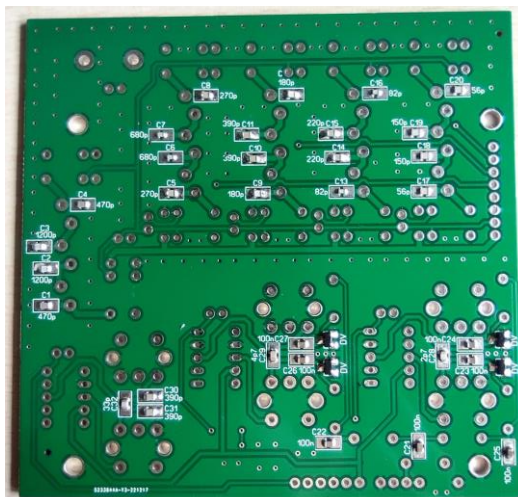

## RECOMMENDED ASSEMBLY SEQUENCE

**All SMD parts soldered at the factory. You don't have to solder anything SMD**

Based on your experience you can place the components in the order you are used to. However I can recommend the following assembly sequence:

- Place and solder D1 10V zener diode.
- Insert and solder all resistors
- Insert and solder the other eight diodes (1N4148) all printed “D” on PCB. They are all placed vertically (see the images).
- Insert and solder all shielded coils (make sure they lie flat on the board). L1 to L4 are 5u3H marked 34. L5 and L6 are 1u2H marked 35.
- Insert and solder toroids (see section “TOROIDS WINDNG”).
- Place and solder all relays. RL1, RL2 RL3 have a printed line that has to match the one printed on the board (see the images).
- Place and solder BNC antenna socket.
- To finish, solder the pins strips. This is important work. See the section “wiring and connections”
- All capacitors are SMD format and are soldered in bottom PCB by [www.ea3gcy.com](http://www.ea3gcy.com) lab.

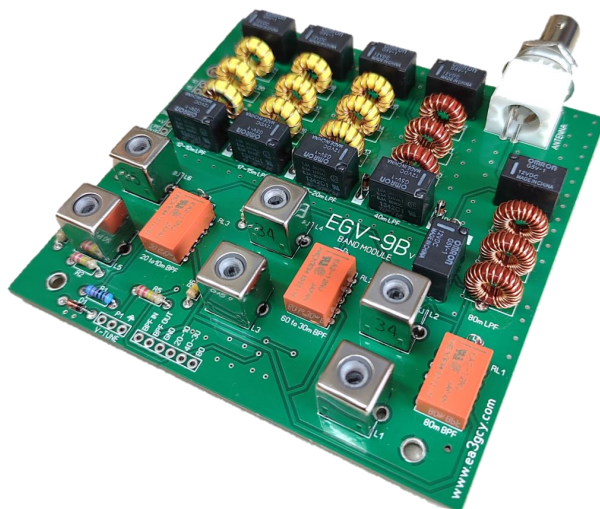

# TOROIDS WINDING

⇒ **T**he following table shows the type of toroid, the turns it has to wind and the length of wire it will need. All toroids are 9.5mm/0.375in outside diameter. The T37-2 toroid is the red one and the T37-6 is the yellow one. 0.4 mm thick enameled wire is used.

TOROIDS TABLE				
TOROID	BAND	TYPE	TURNS	WIRE length (0.4mm Ø)
L7	80	T37-2	25	36 cm
L8	80	T37-2	27	39 cm
L9	80	T37-2	25	36 cm
L10	60-40	T37-2	18	28 cm
L11	60-40	T37-2	20	30 cm
L12	60-40	T37-2	18	28 cm
L13	30-20	T37-6	15	24 cm
L14	30-20	T37-6	16	25 cm
L15	30-20	T37-6	15	24 cm
L16	17-15	T37-6	12	20 cm
L17	17-15	T37-6	14	23 cm
L18	17-15	T37-6	12	20 cm
L19	12-10	T37-6	10	18 cm
L20	12-10	T37-6	11	19 cm
L21	12-10	T37-6	10	18 cm

Note: Lengths are calculated so that you will have some wire left over and easy to pull on.



# TOROIDS ASSEMBLY EXAMPLE:

⇒ The following example is the low pass filter for 40m

## 40m LPF Toroids L10, L11 and L12

- L10 and L12 are identical and are wound with **18 turns**.
- L11 is wound with **20 turns**.

They use T37-2 (red toroids 9.5mm/0.375in outer diameter).

Cut about 28cm (10.3") of 0.4mm diameter enameled wire and wind the **L10 and L11** toroids with eighteen (18) turns. Spread the turns evenly around the toroid and wind them tightly so that they follow the contour of the toroid and are as tight against the toroid as possible. The turns should be evenly distributed around the circumference of the toroid.

Leave pigtails of about 10-12mm (0.70"). Scrape off the enamel with a knife from the ends of the wire, in order to solder the toroid onto the board.

For **L11** cut about 30cm (12") of 0.5mm diameter enameled wire and wind twenty (20) turns. Mount and solder the three toroids in place.

*Counting the turns: Count one turn for each pass of the wire through the center of the toroid.*

Important: Wind the toroid exactly as shown in the images. One turn more or less will affect the transmitter spectrum and the output power.

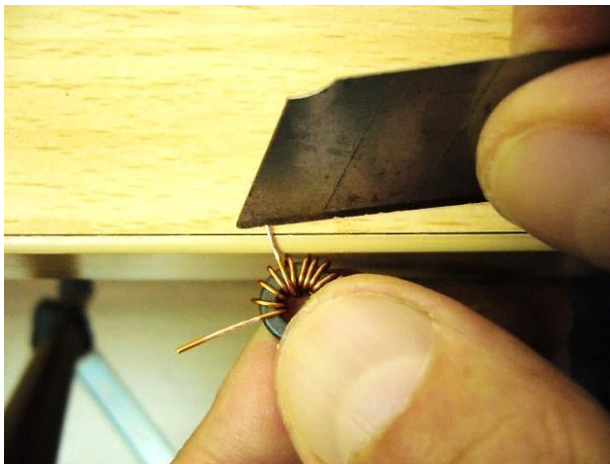
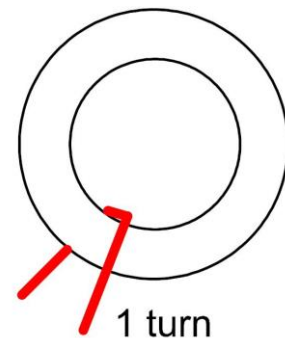
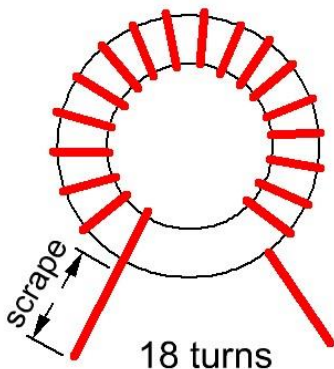

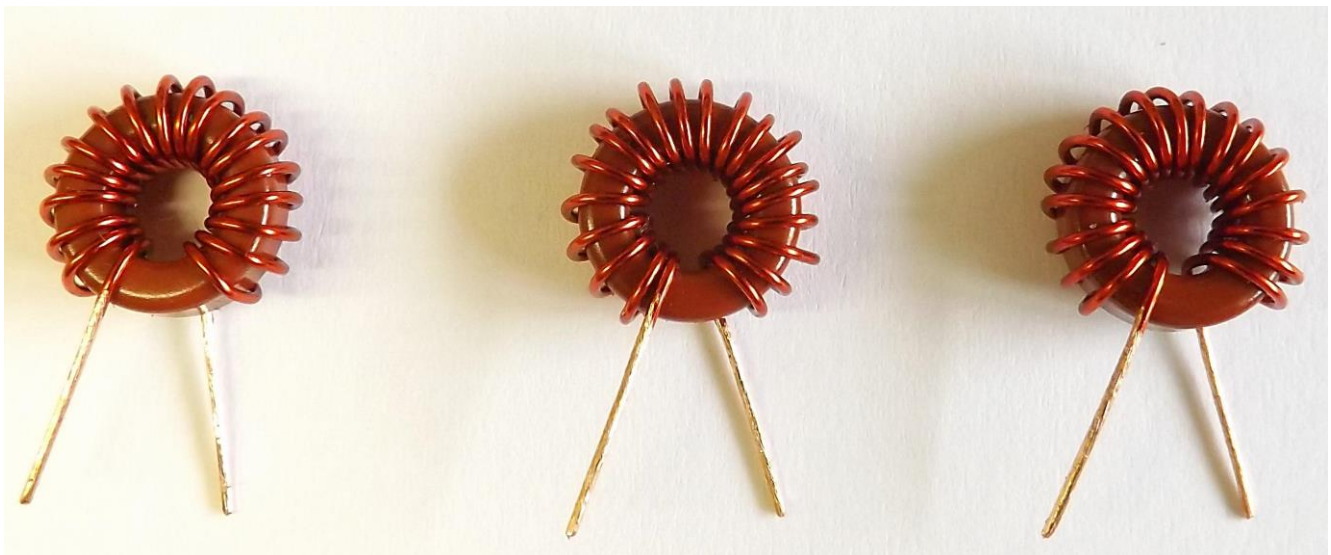

L10 (18 turns)

L11 (20 turns)

L12 (18 turns)

## PLUG IN MODULE - WIRING AND CONNECTIONS

⇒ The EGV-9B\_BPFLPF PCB is a plug-in module that sits on top of the EGV-9B's main board.

***The connection is simple, but requires special attention so that errors do not arise.***

1.- The three-pin “V-TUNE” strip goes up and is soldered to the bottom side of the board.

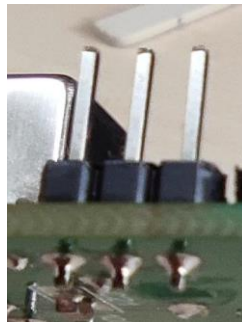

2.- The other two strips of pins go down (to connect to the main board) and are **soldered to the top side of the board**. Extra-long strips of pins are used. 8 extra-long pins strip for LPF switching and 6 extra-long pins strip for BPF switching.

Before soldering you should pay close attention to how tall the pins should be to accommodate the position of the plug-in board.

- Insert the pins from above the board (Top)
- Next put the board in place no solder the pins.
- Insert the pins into the female sockets of the main board all the way down.
- With a fine soldering iron tip, **solder the pins on the top of the board**.
- Although it is not necessary, you can later tear off the plastic strip



See the following pictures:

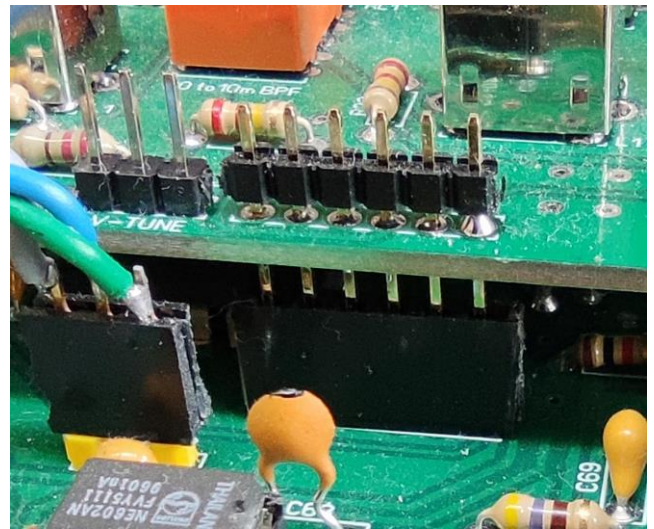
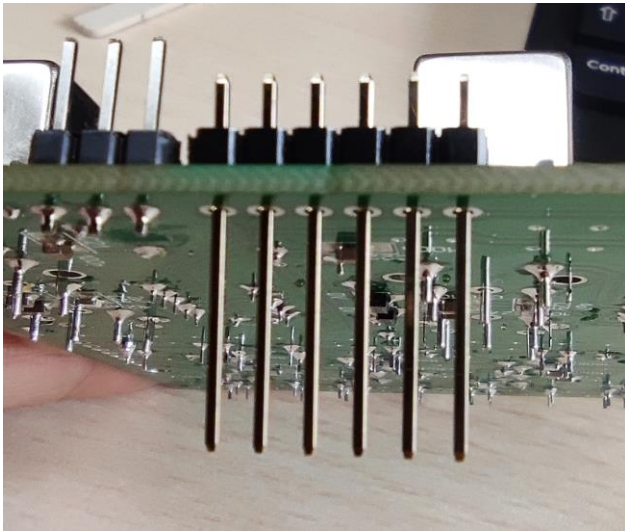

The spacers to screw the board are 10mm and you have to add a nut to gain about 2mm in height. To fasten to the main board, 10mm (M3x10) screws are used and to fasten the plug-in filter module, 4 or 5mm (M3x4) screws are used. See the images.

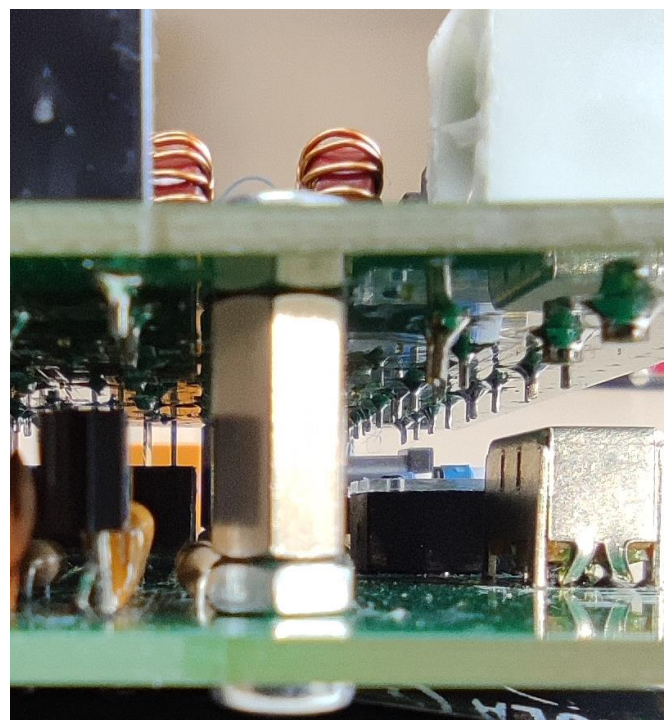
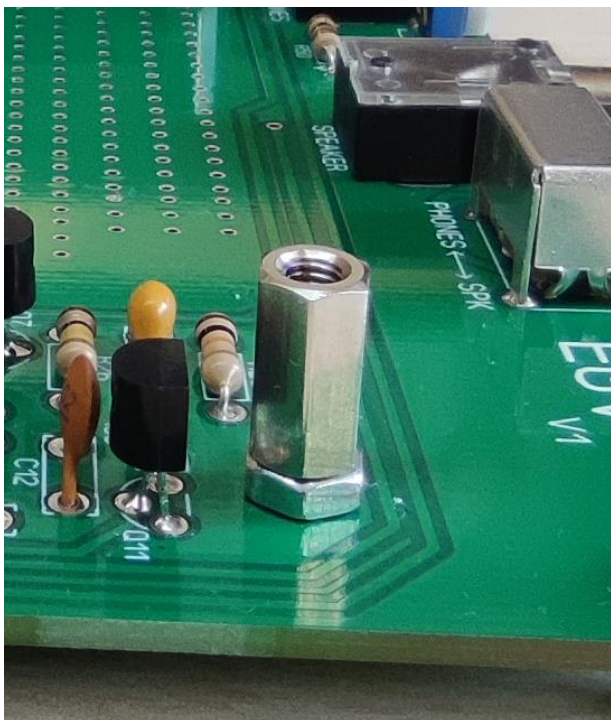

# SETTINGS AND TESTS

⇒ **P**lease, refer to the **EGV-9B** main board manual for **L1** to **L6** adjustment and checks.

## LIMITED WARRANTY

**Please read carefully BEFORE building your kit**

All electronic components and hardware supplied with the kit are under warranty in case of any manufacturing defect for the period of one year after purchase. The warranty does not include the transmitter final amplifier transistor.

The original purchaser has the option of examining the kit and manual for 10 days. If, within this period, the buyer decides not to build the kit, he/she may return the entire unassembled kit at their own expense for the shipping expenses. The shipping expenses and sales commissions (i.e. bank, Ebay, and PayPal commissions) included in the purchase price will not be returned.

Please, BEFORE returning a product, request instructions by email at: [ea3gcy@gmail.com](mailto:ea3gcy@gmail.com)

Javier Solans, EA3GKY, warrants this device to function according to the specifications, provided that it is assembled and adjusted as described in this documentation, and used correctly according to all provided instructions.

It is your responsibility to follow all the instructions in the manual, to identify all the components correctly, and to use good workmanship and proper tools and instruments in the construction and adjustment of this kit.

REMEMBER: This kit will not work as a commercially manufactured product; however, it can often give similar results. Do not expect great performance, BUT YOU ARE SURE TO HAVE LOTS OF FUN!

If you believe that there is a missing kit component, please do a thorough inventory of all parts using the parts list in the manual. Check all bags, envelopes and boxes carefully. If needed, you may email me and I will replace any component that you are missing. Even if you can find the exact part locally, please let me know so that we are aware of the problem to help other customers.

I can also supply any part that you have lost, damaged or broken accidentally.

If you find any errors in this manual or would like to make a comment, please do not hesitate to contact me at [ea3gcy@gmail.com](mailto:ea3gcy@gmail.com)

THANK YOU for building the **EGV-9B\_BPFLPF** module kit.

Enjoy QRP!

73 Javier Solans, EA3GKY

# SCHEMATICS

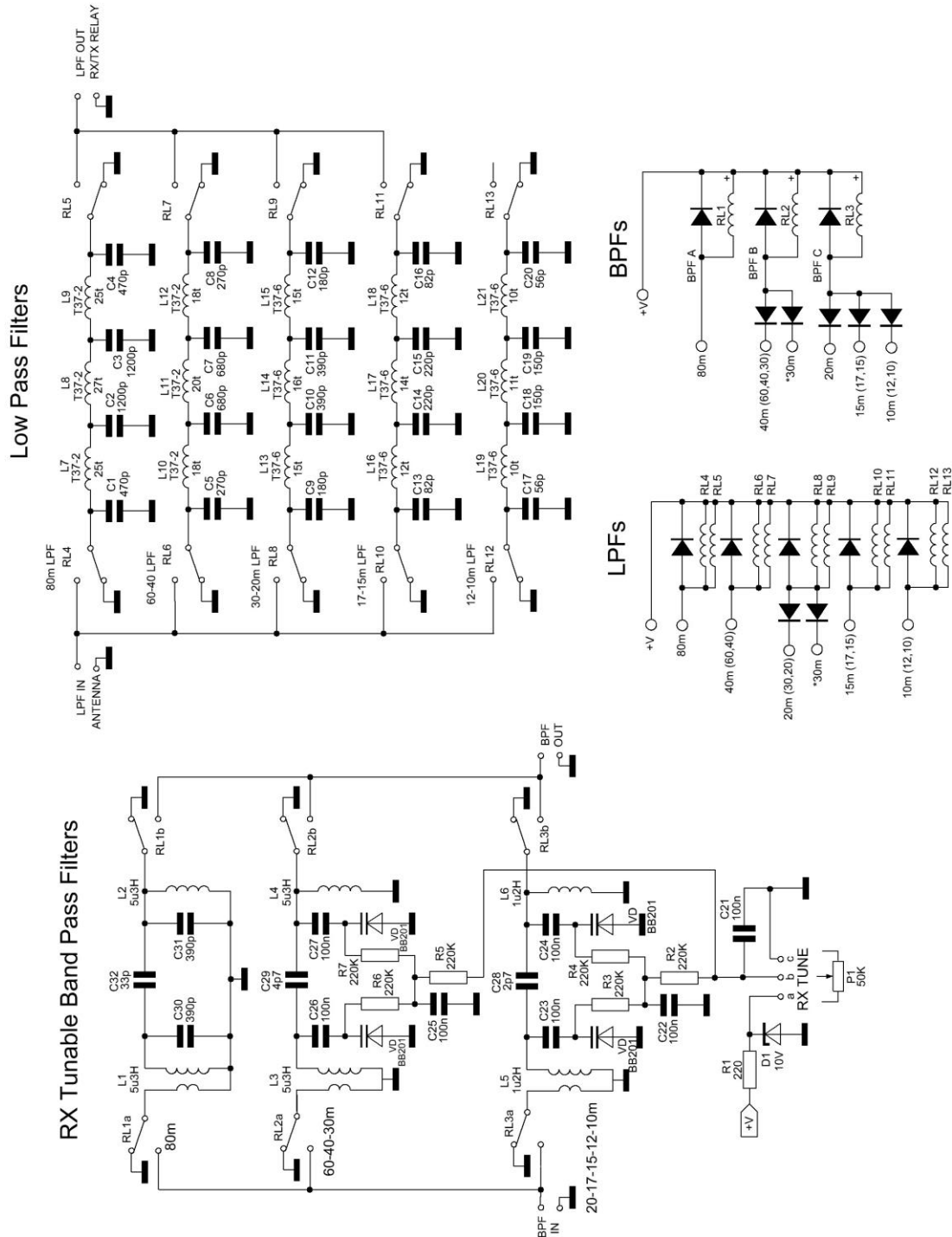

## EGV-9B BPF and LPF

All diodes unmarked are 1N4148

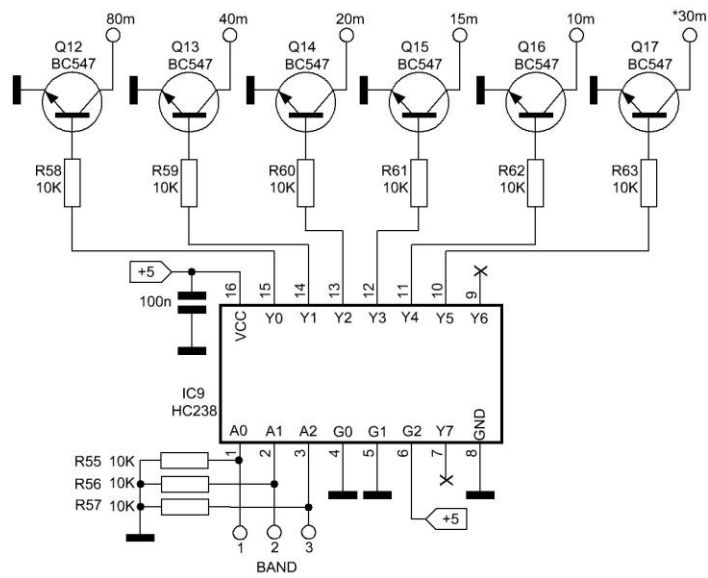

Switching circuit on main PCB

\*30m this is an extra path for 30m  
drive the 60-30m BPF and 20m LPF