

# CW Interface

## for DB4020

CW interface and crystal IF filter module for DB4020 transceiver

### Assembly manual

Last update: February 20 2021

[ea3gcy@gmail.com](mailto:ea3gcy@gmail.com)

Latest updates and news in: [www.ea3gcy.com](http://www.ea3gcy.com)

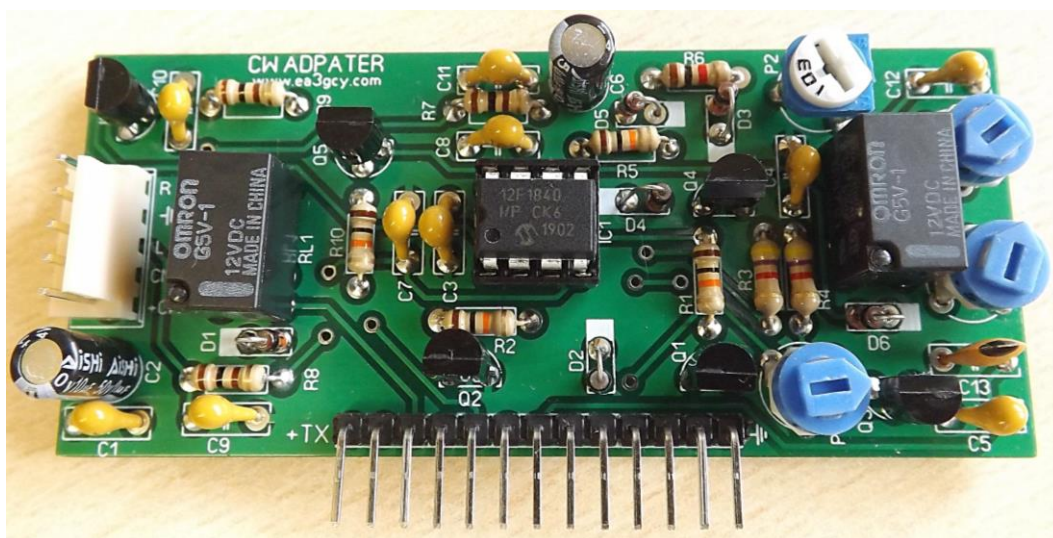

Thank you for building the **CW Interface and IF Filter** kits.

Have fun assembling it and enjoy QRP! 73 Javier Solans, ea3gcy

## CW Interface for DB4020

The "CW Interface" adds CW mode to the DB4020 transceiver kit. It is a complete circuit incorporates an automatic keyer with memories, side-tone monitor, TX / RX delay adjustment, independent signal settings for 40 and 20m, switching for SSB / CW and the necessary control lines for the transceiver processor. A small board is included with the jack for the paddles key, the push button "CMD" and the "SSB/CW" switch.

The pack also includes an I.F. filter plug-in for CW. This filter has a narrow bandwidth about 500-600Hz which greatly improves the CW signals reception.

## CW Interface module COMPONENT LIST

CW Adapter module				
Qty	Value	Checked	Ref.	Identified
4	10K		R1,R2,R5,R10	brown-black-orange
2	4K7		R3,R4	yellow-violet-red
1	1K		R6	brown-black-red
3	100 Ω		R7,R8,R9	brown-black-brown
1	100Ω		P1 adjustable resistor	101
1	10K		P2 adjustable resistor	103
2	1K		P3,P4 adjustable resistor	102
10	100n		C1,C3,C4,C5,C7,C8,C9,C10,C11,C12	104 or 0.1
1	82p		C13	82
2	10uf		C2,C6 electrolytic	10uf
6	1N4148		D1,D2,D3,D4,D5,D6	1N4148
5	BC547		Q1,Q2,Q3,Q4,Q5	BC547
1	KB2		IC1	
1	78L05		IC2	
2	G5V 12V		RL1,RL3 (RL2 does not exist)	Omron relay G5V-1 12V
1	8 pins IC socket		8 pins socket for KB2 chip	
13	45° pins strip		13 male elbow strip	--
1	Male pin socket		5 pin male polarized socket	--
1	SPDT panel switch		SPDT panel switch	--
1	Jack socket		Panel Jack stereo socket	--
1	Push switch		Push panel switch (CMD)	--
1	PCB		PCB (printed circuit board)	--

Socket and switch PCB				
Qty	Value	Checked	Ref.	Identified
1	Push-button		Mini Push-button	--
1	CW/SSB switch		CW/SSB switch	--
1	3.5mm Jack socket		3.5mm stereo Jack socket for paddles key	--
1	Male 5 pin socket		5 pin male polarized socket	--
1	Male 2 pin socket		2 pin male polarized socket	--
2	PCB nylon bracket		Nylon bracket to support PCB	--
4	Self-tapping screws		Self-tapping screws	--
1	PCB		PCB (printed circuit board)	--

## CW IF filter module COMPONENT LIST

CW IF filter module				
Qty	Value	Checked	Ref.	Identified
1	1K5		R1	brown-green-red
1	100n		C1	104 or 0.1
3	180p		<b>C2, C3, C4 (see text)</b>	180J or 181
1	1N4148		D1	4148
1	BC547		Q1	BC547
3	4.915MHz		X1, X2, X3	4.91 or 4.915
2	G5V 12V		RL1, RL2	Omron Relay
7	Pins strip male		4 + 3 EXTRA LONG pins strip	--
7	Pins strip female		4 + 3 female strip pins	--
1	PCB		PCB (printed circuit board)	--

**PLEASE READ ALL ASSEMBLY INSTRUCTIONS COMPLETELY AT LEAST ONCE BEFORE YOU BEGIN.**

## RECOMMENDED MOUNTING SEQUENCE

It is recommended to carry out the assembly work on “**CW Adapter**” PCB. Use the parts list in the following order:

- 1 Following the components list, solder resistors.
- 2 Place and solder the adjustable resistors P1, P2, P3 and P4.
- 3 Install and solder diodes D1 through D6. All are 1N4148.
- 4 Next install and solder capacitors. The C2 and C6 are electrolytic capacitors and must be placed with their longest terminal coinciding with the “+” sign printed on the board.
- 5 Place and solder transistors. All are BC547
- 6 Place and solder the IC1 socket and insert 12F1840 (KB-2 chip). Place and solder IC2 78L05
- 7 Place and solder the header strip pins at the places. As shown in the images.
- 8 Place and solder the relays.

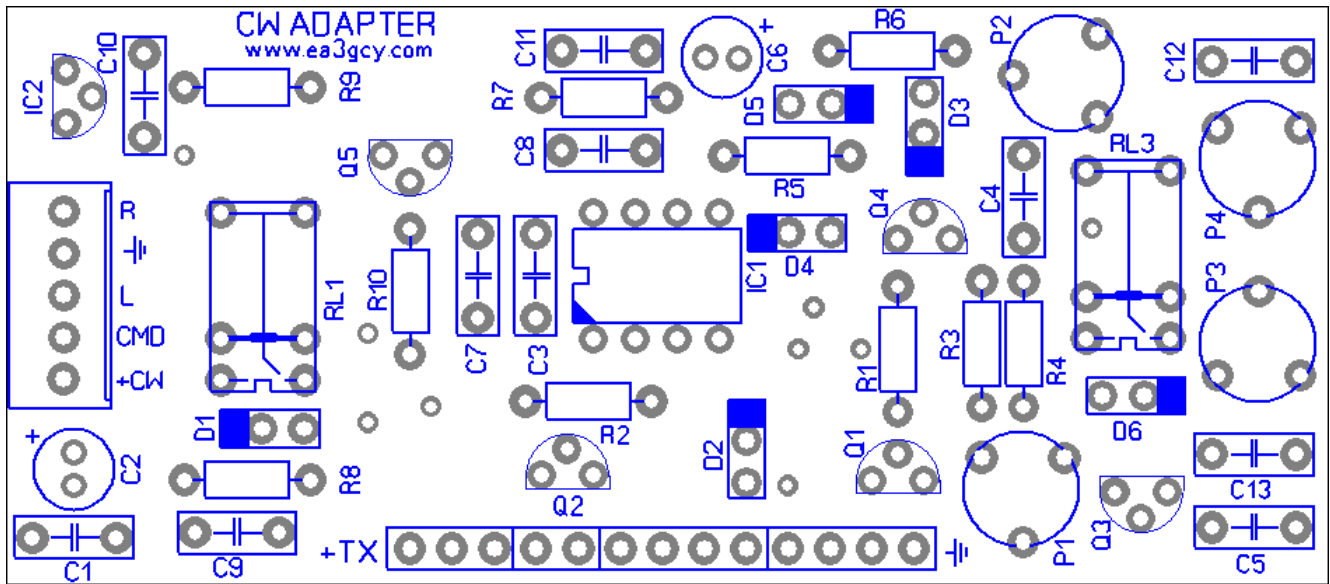

For the “**CW-FL**” filter PCB parts list, follow the same order as above.

**Note:** Extra long pin strips are used in the filter board. See the images.

**Note about C2, C3 and C4:** You can decrease the filter bandwidth by changing C2, C3 and C4 to 390p or 470p. Attenuation also increases slightly (kit includes 3 of 470pf extra capacitors).

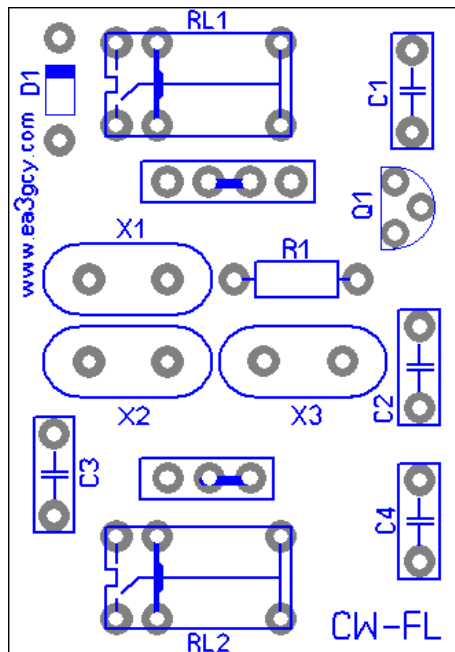

## SETTINGS

P1 Adjust the side-tone monitor level.

You can start by adjusting to 75% (clockwise).

P2 Adjust the TX to RX delay

You can start by adjusting to 50% (clockwise).

P3 Adjust the 40m power signal level.

You can start by adjusting to 25% (clockwise).

P4 Adjust the 20m power signal level.

You can start by adjusting to 50% (clockwise).

## WIRING

### CW Interface wiring

The only connections that have to be made are those that go from the interface module to the control panel elements and to +V

- Push button “**CMD**”
- Jack input for paddles key. Right and Left paddles “**R**” – “**L**”
- Power supply to “**+ CW**”
- “**GND**”

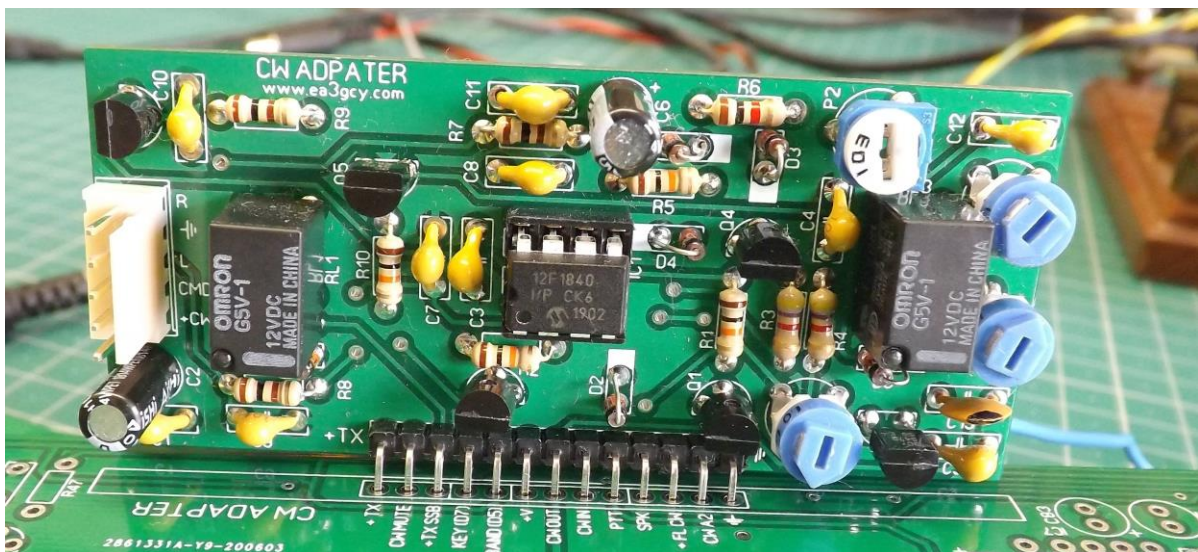

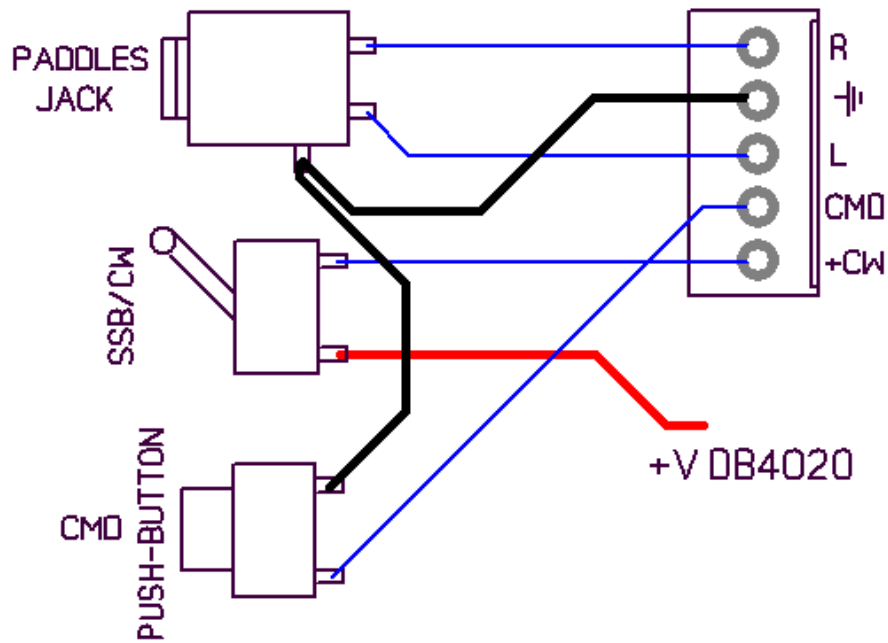

You can install the PCB supplied in the kit with the 3.5mm Jack socket, the "SSB / CW" switch and the "CMD" Push-button or use your own elements adapted to your particular installation.

Note: The switch marked ON / OFF is the one that switches SSB / CW.

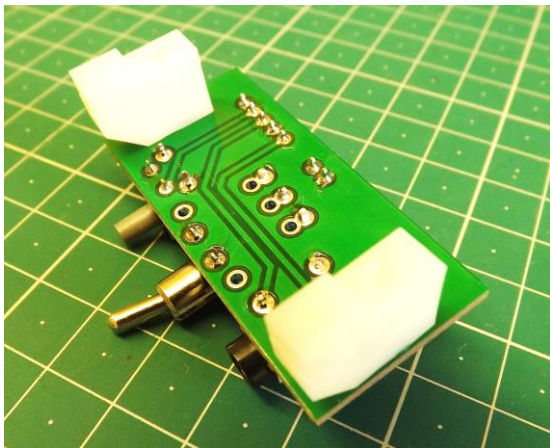

Wire from the 5-pin socket to the 5-pin socket on the "CW Interface" board.

The **+** pin of the 2-pin socket goes to the **+** of the DB4020's general power input socket (or to the ON / OFF switch if using one). The **GND** pin of the 2-pin socket does not need to be connected as it is also taken in the 5-pin socket.

## IF CW Filter plug-in

The CW IF filter is a plug-in board. You must solder extra long pin strips as seen in the picture.

You can solder the female pin strips (4 + 3) to the DB4020 board to plug in the filter.

The other alternative is to directly solder the filter to the existing male pins, so the filter will be permanent.

Make sure the bottom board layer does not touch the SSB filter crystals.

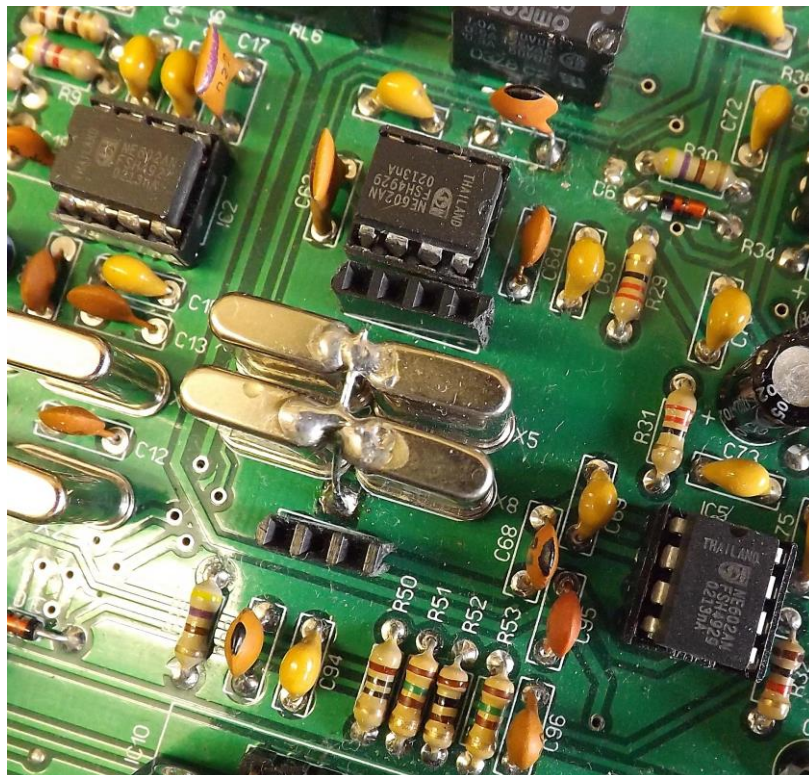
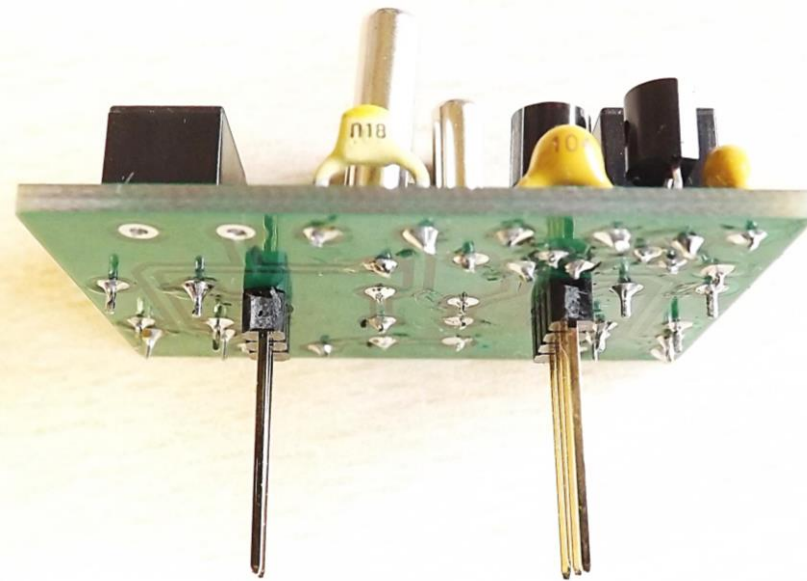

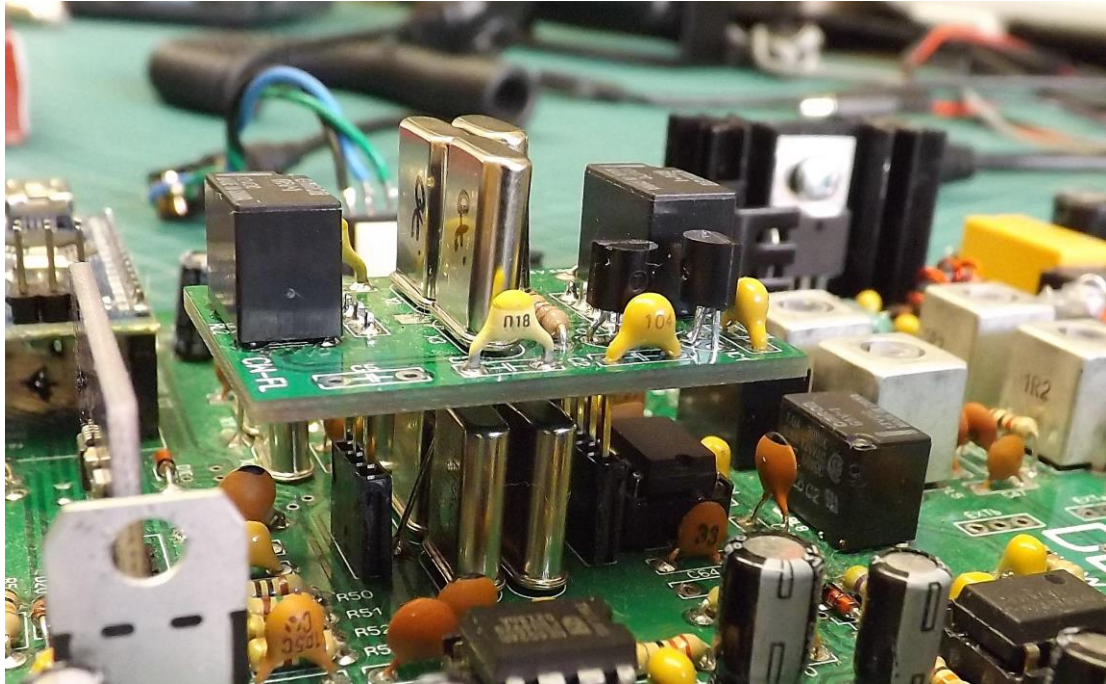

**Note:** It is not planned to disconnect the filter while working in CW mode. However, you could disconnect the “+ FL CW” pin from the interface module and insert a manual switch. This way you could connect / disconnect the RL1 and RL2 relays of the filter (filter ON/OFF).

## **J2 Jumper on DB4020 transceiver board.**

J2 jumper supplies power to the SSB modulator circuit when the “CW Interface” is not available. When the “CW Interface” is plugged-in then the feeding for SSB is done automatically from CW adapter module (in CW mode the SSB modulator is not powered).

**When using the CW Interface, the J2 must be removed.**



# SCHEMATICS

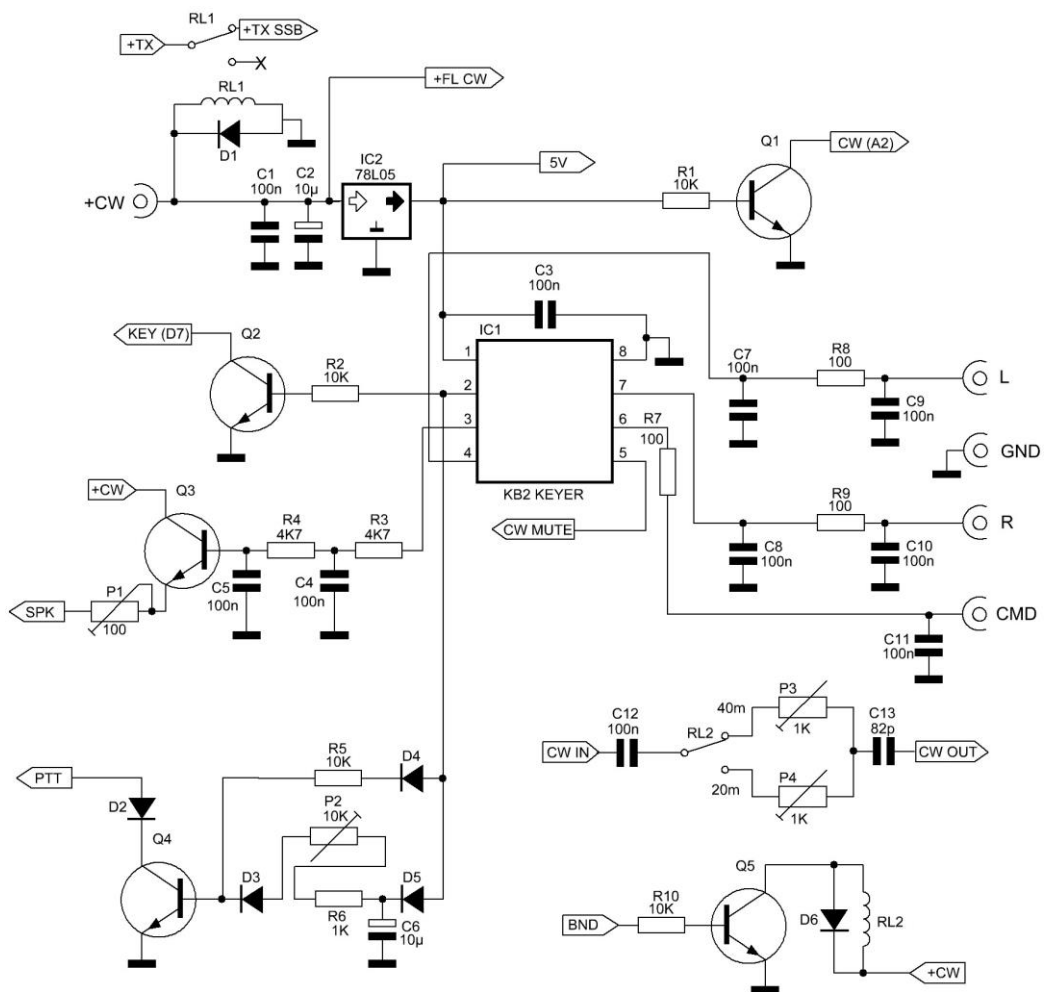

CW INTERFACE

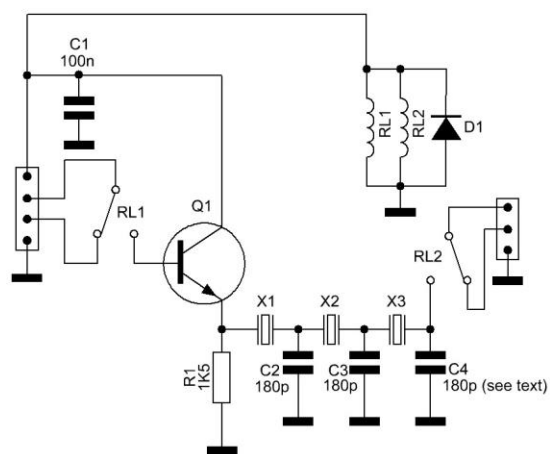

CW FILTER

## KB2 KEYER

The CW Interface keyer is the "KB2" chip which is the same chip used by the "KB-2 CW keyer / beacon" kit ([www.ea3gcy.com](http://www.ea3gcy.com)). Therefore, the functions and characteristics of the CW Interface for the DB4020 are the same as the KB-2 kit.

Note: For the first tests, you may prefer to use a straight key or a simple switch. See the "Straight Key function" paragraph at the end of this chapter.

**PLEASE READ THOROUGHLY ALL THE FUNCTION'S MANUAL AT LEAST ONCE BEFORE YOU START USING IT.**

### NORMAL OPERATION:

#### Conventions

- When we enter a command, the keyer will respond with "R" (except in the commands that invert the current state, actual "A", "D", "K", "L").
- It will also respond with "R" when we send a digit and do not wait for anything else (example: the message number in the "B" command).
- When the keyer receives a digit that he does not understand or that is not what he expects at that moment, he will respond with "NO".
- The commands and letters or numbers input to programming are always entered with keyer in mode A.
- All commands that make an inversion of the state of a function, if the activation occurs, the keyer responds with "Y" (Yes) and if the deactivation occurs it responds with "N" (No).

#### Messages playback

The playback is very comfortable and effective, but you should carefully follow the procedure indicated below. Once you have practiced a few times, you will see be extremely simple.

##### Message 1

Press the CMD button for <1 second. The keyer transmits the message M1.

##### Message 2

First, press and hold CMD button and before 2 seconds we press and hold the dash paddle, then wait more than >2 seconds. Next, let's release the CMD button first, wait a few moments and then let go of the paddle. Transmission of the M2 message starts.

##### Message 3

First, press and hold CMD button and before 2 seconds we press and hold the dot paddle, then wait more than >2 seconds. Next, let's release the CMD button first, wait a few moments and then let go of the paddle. Transmission of the M3 message starts.

##### Message 4

First, press and hold CMD button and before 2 seconds we press and hold both dash and dot paddles, then wait more than >2 seconds. Next, let's release the CMD button first, wait a few moments and then let go of the paddles. Transmission of the M4 message starts.

##### Stop a message

Press and hold any paddle or CMD button until playback stops.

## COMMAND LIST:

### Command mode

To enter command mode:

**We press the CMD button for more than 2 seconds until the keyer answers "R" indicating that it waits for command.** The keyer waits for 2 seconds for a command to be entered, if nothing is received it sends "NO" and returns to normal keyer mode. If an unknown command is received, it goes out in the same way by sending "NO".

Before entering the letter of the command, you must enter command mode (press CMD until "R" sounds).

### "A" Enable/Disable the monitor local tone.

We enter "A". If it was activated, it deactivates it and the keyer sends "N". If it was disabled, will activate it and send "Y".

### "B" Indicates which message will act as a beacon.

We program what message the "1", "2", "3" or "4" will act as a beacon.

*If we enter "0", no message will act as a beacon.*

Enter "B", the keyer answers "R". We enter the message number we want to act as a beacon (1, 2, 3 or 4). The keyer will respond with "R".

To stop the playback of a message in Beacon mode:

Press and hold any paddle or CMD button until playback stops.

Related commands: "C", "D"

**NOTE:** You can use the beacon to repeat a message when working normally. The automatic beacon must be deactivated (command "D") so that it does not activate automatically when the equipment is switched on.

### "C" Adjust the time between repetitions of the beacon.

Adjust the time between beacon repeats from 00 to 99 seconds

We enter "C" and the keyer responds with "R" and waits for us to enter two numbers from 01 to 99.

Within 2 seconds we have to **enter the first number (tens) and wait for the keyer to respond with an "E"**. Next, we have 2 seconds to **enter the second number (units), then the keyer responds with "R"** and exits the command mode.

**Attention:** you should always enter two numbers. For example, for 5 seconds you must enter "0" and then "5".

### "D" Enable/Disable Automatic Beacon mode.

Enter "D". If it was activated, it deactivates it and the keyer sends "N". If it was disabled, will activate it and send "Y".

*The Automatic Beacon makes the keyer always work in Beacon mode when it starts up.*

For the automatic beacon to work, the "B" command is used with the message that you want to be the beacon and the "C" command with the time between beacon repetitions.

### "E" Adjust PPM speed of the keyer with the paddles.

Enter "E", answer with "R" and then with the paddle dash increase the speed and the paddle dot decrease it. To exit, press and release the CMD button, the keyer will respond with "R".

### "F" Adjust the Sidetone monitor frequency.

Enter "F", answer "R". The Dash paddle increase frequency and Dot paddle decrease.

To exit, press and release the CMD button.

### **"K" Change the keyer mode.**

Enter "K". If it was in A mode it changes to B mode and vice-versa.  
Respond with "A" if mode A is activated or "B" if mode B is activated

### **"L" Enable/Disable KEY output for tests or practices.**

Enter "L". If it was activated, it deactivates it and the keyer sends "N". If it was disabled, will activate it and send "Y".

### **"P" Paddles swap.**

Enter "P". The keyer answer "R" and swap the Dash – Dot paddles or vice-versa.

### **"R" Record the specified memory.**

Recording messages is very convenient and effective, but you should carefully follow the procedure indicated below. Once you have practiced a few times, you will see that it will be extremely simple. To enter messages, you have to change your usual CW transmitting way and listen carefully to the keyer's response signals. To make it easier for messages enter, it may be a good idea to reduce PMM speed ("E" or "S" commands)

Enter to command mode (press CMD until "R" sounds).

Enter "R", the keyer respond us "R". We enter the memory number we want to record (1, 2, 3 or 4), the keyer responds with "R". Next we will enter the message.

The steps to enter a message are the following:

*1.- Before 2 seconds we enter a CW carácter (letter, number or punctuation mark).*

*2.- We hope it sounds a point (letter "E").*

*We will repeat the previous two steps 1 and 2, entering characters until a word ends*

.....

*When you want to insert a space between words, do not enter anything after hearing the point (E) and wait 2 more seconds until you hear three points (S) and then continue entering the letters of the next word.*

*When the message is finished, stop entering anything and wait ... You will hear point (E), then the three points (S) and then you will hear "END",*

Each message allows the entry of 60 characters including the spaces between words.

### **"S" Adjusts the speed of keyer transmission in PPM (from 01 to 50)**

We enter "S" and the keyer responds with "R" and waits for us to enter two numbers from 01 to 50. Within 2 seconds we have to enter the first number (tens) and wait for the keyer to respond with an "E" point. Next, we have 2 seconds to enter the second number (units). Then the keyer responds with "R" and exits the command mode.

**Attention:** You should always enter two numbers. For example, for 8 PPM you must enter "0" and then "8".

### **"T" Tune.**

Enter "T", the keyer respond R and will activate the KEY output. The Dash paddle acts as OFF and the Dot paddle as ON. To exit tune mode, press and release the CMD button

## OTHER FUNCTIONS

### RESET

The RESET has no command. It is done by connecting the KB-1 power supply while pressing the CMD button. The parameters after the RESET are:

Keyer MODE = Mode B  
PPM = 18 words / minute  
Keyer Output = Enabled  
Monitor = Enabled  
Output keyer command monitor = Disabled  
Swap Paddles = Normal  
Automatic Beacon = Disabled  
Monitor Tone frequency = 700Hz  
Beacon = Disabled  
Beacon interval repetition = 4 segundos  
Messages= It maintains the existing ones before the "reset".

### Delete a message.

It is unusual for you to need to delete a message, because when you record a new message, the previous message is deleted. However, if you want to leave a message "blank", enter the "R" command and the message number as if you will record a message normally, but do not enter any character in the message and wait to hear "END". That message will be deleted.

### Automatic Beacon Function.

The Automatic Beacon makes the keyer always work in beacon mode when it starts up. This function converts the KB-2 keyer into a universal generator of morse signals for beacon. To work as Automatic Beacon, you must perform the following steps:

- Record the message destined to Beacon in one of the memories ("R" command).
- Then you must select that message to act as a beacon ("B" command).
- Set the interval time between repetitions ("C" command).
- Activate the Automatic Beacon function ("D" command).

**Note:** if you do not select Automatic Beacon ("D" command) the beacon will act when you press the CMD button, but it will not start automatically when the keyer is turned ON.

### Straight Key function

When the system starts, it check the middle ring of the input jack, if it is connected to GND, then it consider that a straight key will be used. See the image.

With a straight vertical key you can't enter commands or program the keyer, so you will need a paddles keyer to enter commands and record messages.

However, you can send # 1message "M1" by pressing CMD. To stop playing the message, press CMD again.

Note: You can program a paddle from a paddle keyer to act as a vertical key simply by holding a paddle tight while power up KB-2 circuit (this setting is not maintained when turning off the power to the KB-2 circuit).



Paddles keyer Jack (stereo)



Straight keyer Jack (stereo or mono)

# LIMITED WARRANTY

## Please read carefully BEFORE building your kit

All electronic components and hardware supplied with the kit are under warranty in case of any manufacturing defect for the period of one year after purchase. The warranty does not include the transmitter final amplifier transistor.

The original purchaser has the option of examining the kit and manual for 10 days. If, within this period, the buyer decides not to build the kit, he/she may return the entire unassembled kit at their own expense for the shipping expenses. The shipping expenses and sales commissions (i.e. bank, EBay, and PayPal commissions) included in the purchase price will not be returned.

Please, BEFORE returning a product, request instructions by email at: [ea3gcy@gmail.com](mailto:ea3gcy@gmail.com)

Javier Solans, EA3GCY, warrants this device to function according to the specifications, provided that it is assembled and adjusted as described in this documentation, and used correctly according to all provided instructions.

It is your responsibility to follow all the instructions in the manual, to identify all the components correctly, and to use good workmanship and proper tools and instruments in the construction and adjustment of this kit.

REMEMBER: This kit will not work as a commercially manufactured product; however, it can often give similar results. Do not expect great performance, BUT YOU ARE SURE TO HAVE LOTS OF FUN!

If you believe that there is a missing kit component, please do a thorough inventory of all parts using the parts list in the manual. Check all bags, envelopes and boxes carefully. If needed, you may email me and I will replace any component that you are missing. Even if you can find the exact part locally, please let me know so that we are aware of the problem to help other customers.

I can also supply any part that you have lost, damaged or broken accidentally.

If you find any errors in this manual or would like to make a comment, please do not hesitate to contact me at [ea3gcy@gmail.com](mailto:ea3gcy@gmail.com)

THANK YOU for building the **CW Interface for DB4020** kit.

Enjoy assembly!

73 Javier Solans, EA3GCY