

BP-1A

Band-Pass variable filter continuous tuning from 3 to 30MHz.

For analogue or software-defined receivers (SDR)

Assembly manual

Last updated: November 20, 2017

ea3gcy@gmail.com

Updates and news at: www.qrphamradiokits.com

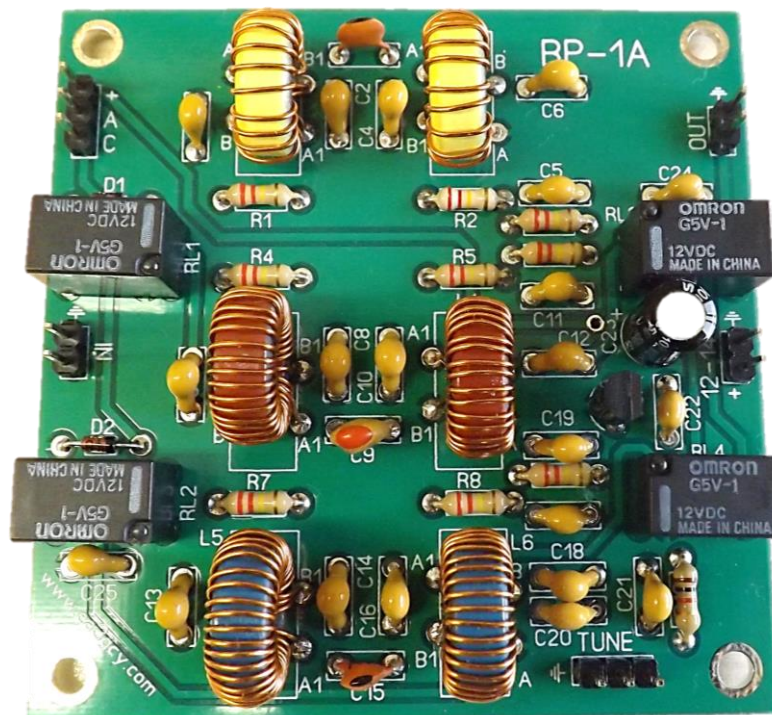

Thanks for building the BandPass variable filter **BP-1A** kit

Have fun assembling it ! 73, Javier Solans, ea3gcy

PLEASE READ ALL OF THE ASSEMBLY INSTRUCTIONS COMPLETELY AT LEAST ONCE BEFORE BEGINNING.

SPECIFICATIONS

- Band Pass filter from 3 to 30Mhz continuous with manual tune.
- Three tuning margins: from 3 to 6MHz, 6 to 12MHz and 12 to 30MHz.
- Manual control via potentiometer.
- Dual LC filter for each margin composed of toroids and varactors.
- Suitable for analogue or software-defined receivers (SDR), HF instrumentation, RF experiments in laboratories, etc.
- Input and Output impedance: 50ohms.
- Power supply: 12 -14V
- PCB size: 70 x 70 mm.

WHAT BP-1A DOES

The BP-1A kit is a 3 to 30MHz continuous bandpass filter. It is intended to improve the front stage in analog receivers or SDR (software defined receivers), experiments in radio laboratories, measuring instruments etc. where a filter is required to select any frequency segment within of 3 to 30 MHz range. In particular, medium and low cost SDR receivers need bandpass filters when receiving HF (OC) radio signals.

The BP-1A allows you to tune and select the frequencies of any amateur radio or HF broadcasting band. The tuning is done manually with a potentiometer that allows to be located at any point in the coverage range. The BP-1A incorporates three relay-switched bandpass filters covering from 3 to 6MHz, 6 to 12MHz and 12 to 30MHz.

Each filter is composed of two varicaps tuned RF toroidal transformers with an input and output 50 ohms impedance. A single potentiometer controls the three filters and the switching of the filters is done with a simple three-position switch.

PARTS LIST

Resistors				
	Reference	Value	Component type	Identification
	R1 to R9	220K	220K resistors	red-red-yellow
	R10	1K	1 K resistor	brown-black-red

Capacitors				
	Reference	Value	Component type	Identification
	C1 and C2	100n	100nF capacitors	104 o 0.1
	C3	4p7	4,7p capacitor	4p7 o 4.7
	C4 to C8	100n	100nF capacitors	104 o 0.1
	C9	6p8	4,7p capacitor	6p8 o 6.8
	C10 to C14	100n	100nF capacitors	104 o 0.1
	C15	10p	10p capacitor	10p o 10
	C16 to C22	100n	100nF capacitors	104 o 0.1
	C23	100uF	100uF electrolytic capacitor	100uF
	C24 and C25	100n	100nF capacitors	104 o 0.1

Diodes, regulator and Relays				
	Reference	Value	Component type	Identification
	D1	1N4148	1N4148 diode	4148
	D2	1N4148	1N4148 diode	4148
	IC1	78L08	8V regulator	78L08
	VD1 – VD8	SVC236	SVC236 varicap diode or equivalent	--
	RL1 a RL4	G5V-1 12V	OMRON G5-1 12VDC Relays	G5V-1

Toroids				
	Reference	Value	Component type	Identification
	L1 y L2	T50-6	Yellow Toroid 12.5mm	
	L3 y L4	T50-2	Red Toroid 12.5mm	
	L5 y L6	T50-1	Blue Toroid 12.5mm	

Varius				
	Reference	Value	Component type	Identification
	Pins	---	12 pins strip (3+3+2+2+2)	---
	Separators	---	4 Hexagonal separators 4mm	---
	Screws	M3 x 4	4 M3 Screws 4 mm lenght	---
	Nuts	M3	4 M3 Nuts	---
	Enamelled wire	340cms	340 cms 0,5mm enamelled wire	---
	PCB BP-1A	---	Printed circuit board 70 x 70mm	

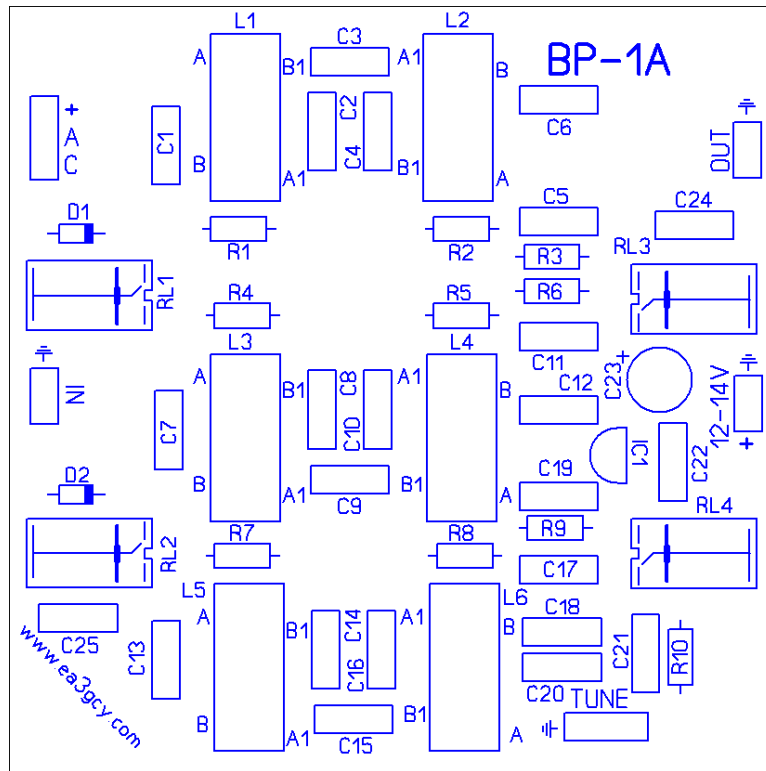

TIPS FOR FIRST TIME BUILDERS

Tools required:

- A fine-tipped 30W soldering iron, good-quality electronic-type solder, small diagonal wire cutters, needle-nose pliers, and tweezers to hold the SMD component.
- You will need good lighting and a magnifying glass to see the fine print on the components and other assembly details.

Soldering:

There are two important things which need to be done to ensure successful operation of a kit. The first is to put the component into the proper place on the circuit board; the second is good soldering.

To solder properly, you must use an electronic-type solder of the highest quality possible and the correct type of iron.

Use a quality-brand soldering iron with a short, fine-pointed tip. For this kit, the soldering iron should be about 30-35 Watts (if it is not thermostatically controlled). Use only high-quality electronic-type solder. NEVER use any extra flux. You should hold the hot soldering iron in contact with both the circuit board and the component lead for about two seconds to heat them up. Then, keeping the soldering iron in place, touch the solder at the junction of the lead and trace and wait about two seconds or so until the solder flows between the lead and the trace to form a good joint. Now remove the soldering iron. The soldering iron should have been in contact with the work piece for a total time of about 4 seconds. When soldering leads that connect to large trace surfaces, you will need to preheat the junction for a little longer so that the solder flows correctly.

You should clean the soldering tip before soldering each joint. This prevents accumulating solder on the tip and mixing in residues from previous soldering operations with the next one.

RECOMMENDED ASSEMBLY SEQUENCE

It is recommended to assemble the kit in the following order:

1. Following the list of components, place and solder all resistors R1 to R10. Make sure they are properly placed on the board as shown in the pictures.
2. Next install and solder C1 to C25 capacitors. The C23 capacitor is an electrolytic type and must be placed with its longest leg to the "+" sign printed on the board.
3. Then place and solder D1 and D2 diodes, pay attention to position them with their correct orientation. There is a strip at one end of each diode that has to match the drawing of the board.
4. Now, place and solder the four relays, make sure that they are flat touching the board.
5. Install and solder the pin terminals on "IN", "OUT", "12-14V", "TUNE" and "A-C"

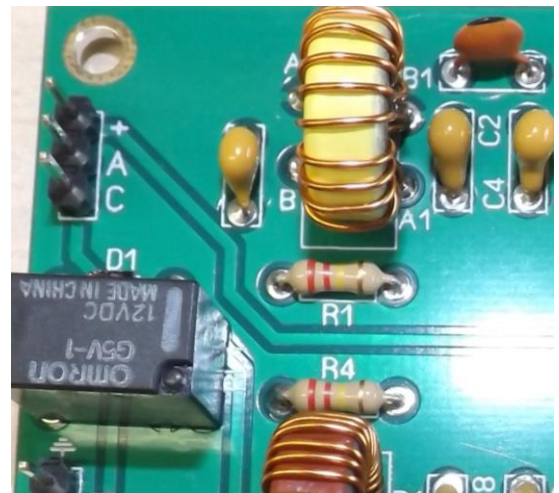
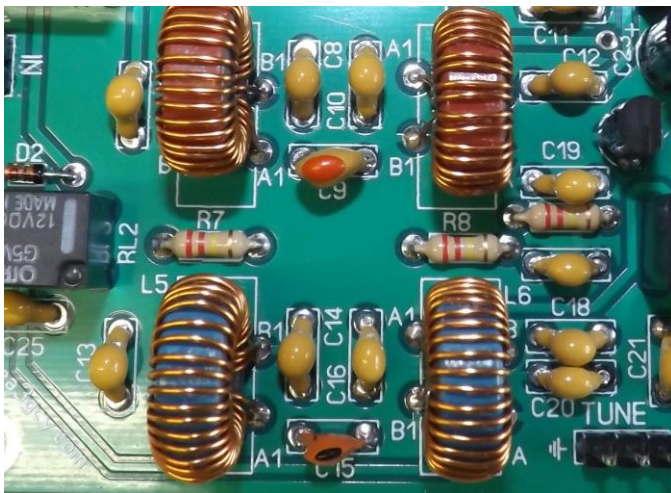

WINDING AND PLACEMENT L1 to L6 TOROIDS

Toroid winding requires special attention. It is not a difficult job but you have to take the time to do it and build the toroids exactly as shown in the following instructions. This is a job that can be very fun if you take it relaxed.

All toroids are wound in the same way, the only difference is the toroid type and the number of turns to be wound.

L1 and L2

L1 and L2 are identical. They use **T50-6 yellow toroid cores** (12.5mm/0.500in OD).

Cut 32cm (12") of 0.5mm diameter enameled wire and wind sixteen (16) turns on toroid core as seen in the images. This will be the winding that will go to the pads "A" and "A1" printed on the board. Spread the turns evenly around the toroid and wind them tightly so that they follow the contour of the toroid and are as tight against the toroid as possible. The turns should be evenly distributed around the circumference of the toroid. Leave pigtails of about 1cm (0.4"). Scrape off the enamel with a cutter from the ends of the wire, in order to solder the toroid onto the board.

Then cut about 5-6 cm (3") of enameled wire and wind two (2) turns as shown in the pictures. This will be the winding that will go to the pads "B1" and "B" printed on the board. See next page.

Counting the turns: Count one turn for every time the wire passes through the center of the toroid.

Important: wind the toroid exactly as shown in the pictures.

One turn more or less will affect the coverage range.

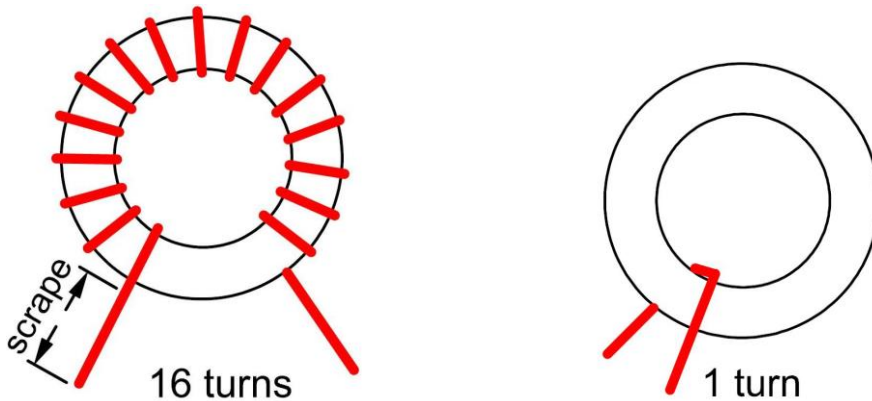

L3 and L4

L3 and L4 are identical. They use **T50-6 red toroid cores**.

Cut about 56cm (22") of 0.5mm diameter enameled wire and wind thirty (30) turns on toroid core as seen in the images. This will be the winding that will go to the pads "A" and "A1" printed on the board.

Then cut about 7-8 cm (4") of enameled wire and wind three (3) turns as shown in the pictures. This will be the winding that will go to the pads "B1" and "B" printed on the board.

L5 and L6

L5 and L6 are identical. They use **T50-1 blue toroid cores**.

Cut about 56cm (22") of 0.5mm diameter enameled wire and wind thirty (30) turns on toroid core as seen in the images. This will be the winding that will go to the pads "A" and "A1" printed on the board.

Then cut about 7-8 cm (4") of enameled wire and wind three (3) turns as shown in the pictures. This will be the winding that will go to the pads "B1" and "B" printed on the board.

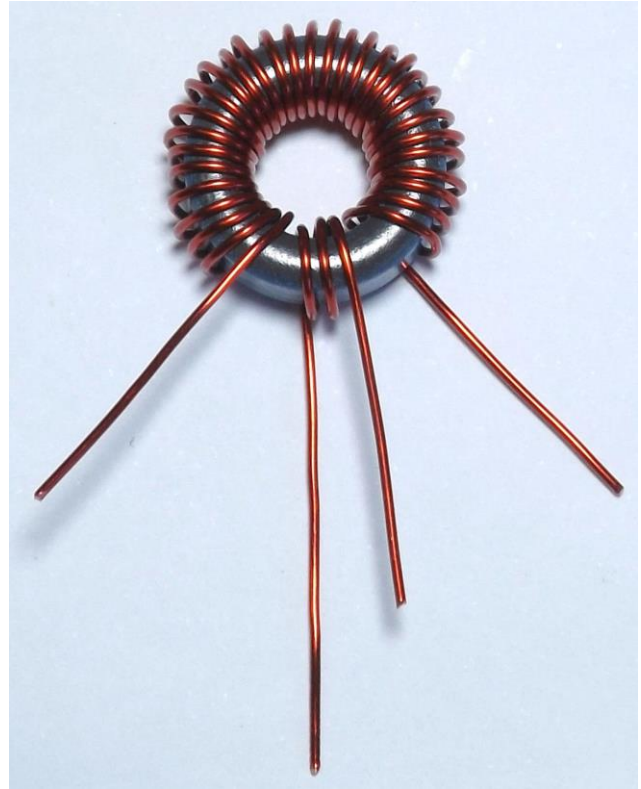
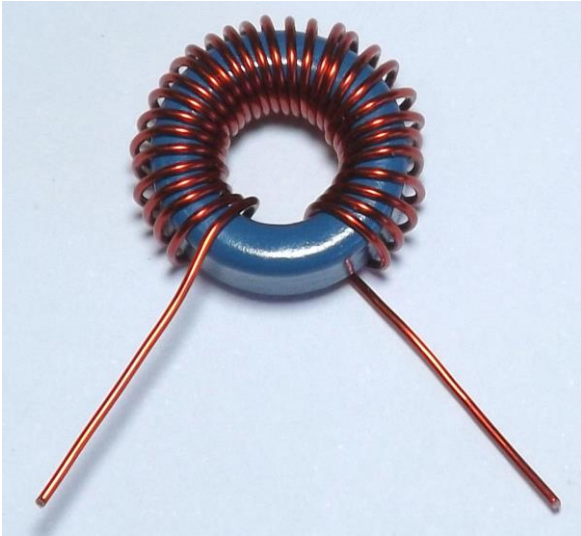

Scrape off the enamel with a cutter from the ends of the wire, in order to solder the toroid onto the board.

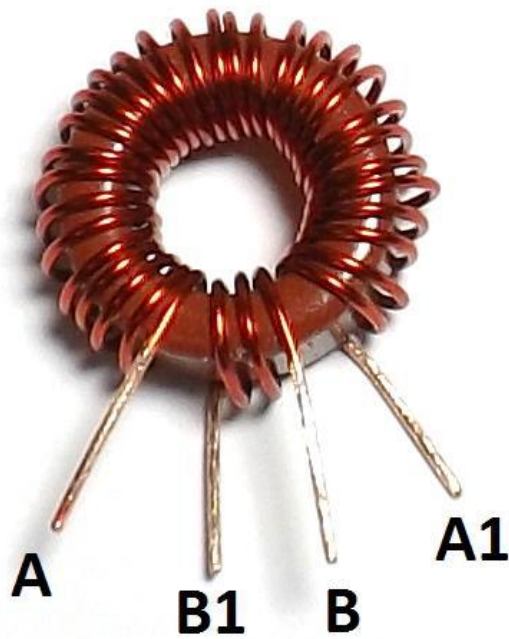

IMPORTANT NOTES:

Count one turn for every time the wire passes through the center of the toroid.

Wind all windings exactly in the direction shown by the images

WIRING

You will need a 1-circuit, 3-position switch to activate the relays and select the desired filter. You can use the miniature toggle switch included in the kit or other types of sliding or rotary switches that you feel better.

Note: The lever switch included in the kit has three positions, the central position is "zero" and does not feed any relay, it will be the position of the range from 12 to 30Mhz (L1-L2).

- When we inject voltage to "A" pin we activate the RL1 and RL3 relays that select the filter formed by L1 and L2 toroids that cover the 12 to 30MHz range.
- When there is no voltage in any relay, the filter selected is the L3-L4 toroids that cover from 6 to 12 MHz range.
- When we inject voltage to "C" pin we activate the RL2 and RL4 relays that select the filter formed by L5 and L6 toroids that cover the 3 to 6MHz range.

Powered terminal (+)	Relays activated	Coverage range
"A"	RL1 and RL3	12 to 30MHz
None	None	6 to 12MHz.
"C"	RL2 and RL4	3 to 6MHz.

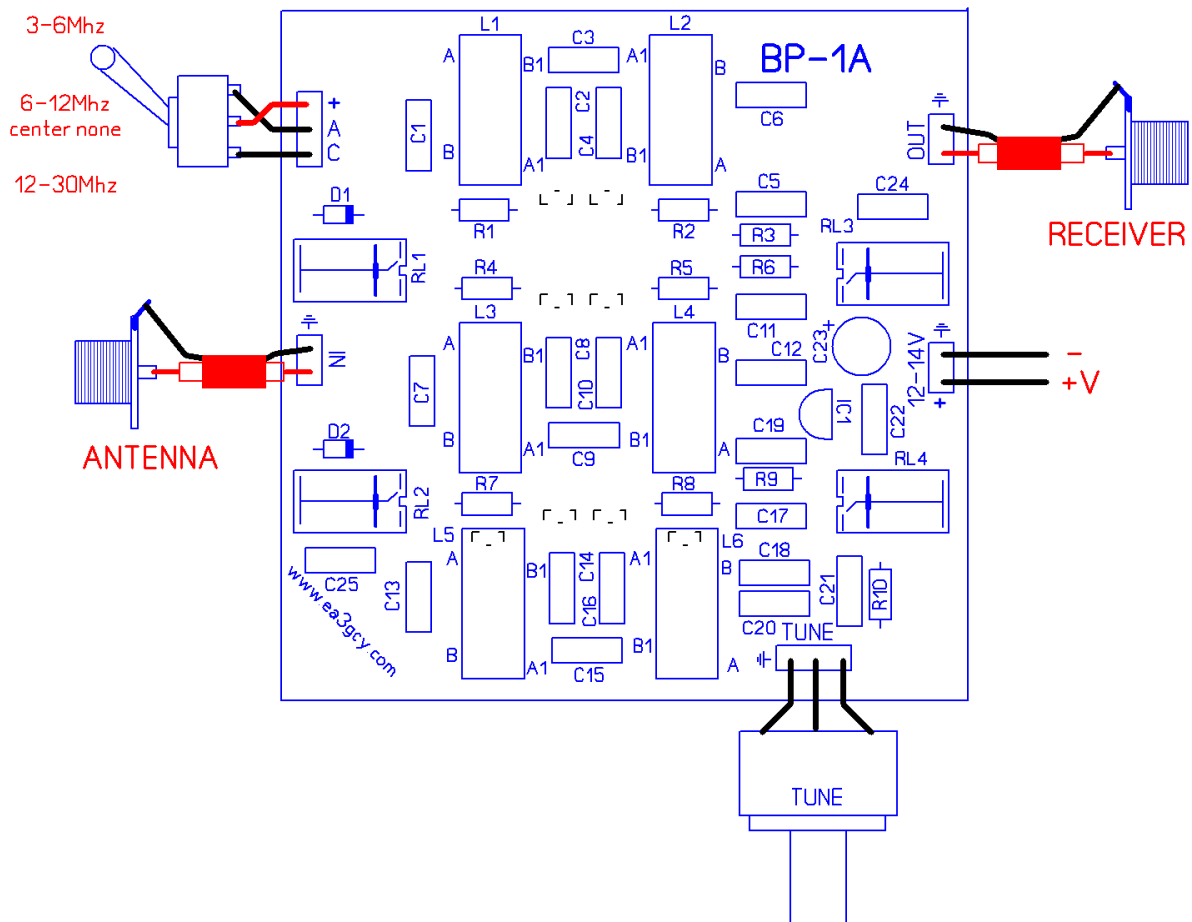

The antenna input is marked "IN" and the output to the receiver is marked "OUT" (use 50ohms coaxial cable for both connections)

The 12 to 14V power supply is connected to the "12-14V" terminals.

BOX ENCLOSURE FOR BP-1A

The following images show some ideas on how to install and wire the BP-1A in its box.

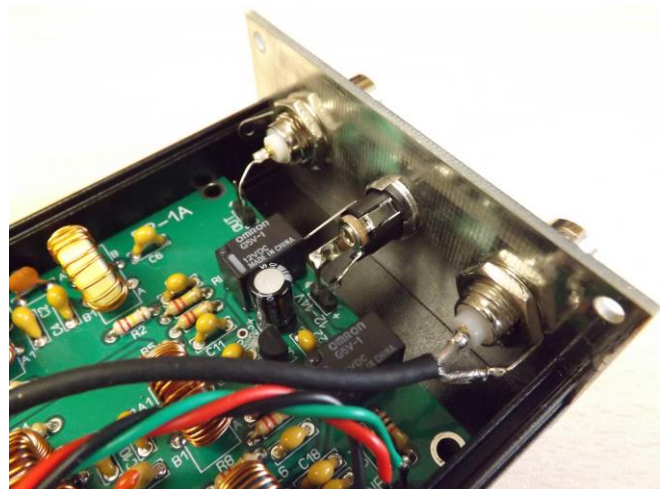

SOME IDEAS FOR USE

In practice, the use of the BP-1A is very simple. If you have an SDR receiver you can see the tuning spectrum on your display in used software.

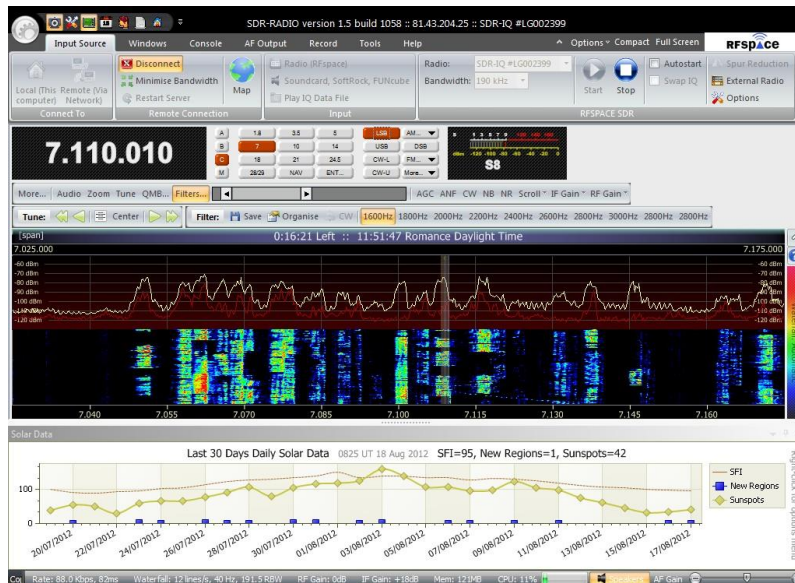

It will also be very easy to calibrate the scale of the "TUNE" knob, noting the corresponding frequencies of the tuning positions.

If you don't have an SDR receiver, then you can use a conventional analog receiver that covers the frequency from 3 to 30MHz. and note the correspondence between the position of the "TUNE" knob and the tuning frequency of the filter.

A table of 3 to 30MHz in steps of 1MHz showing the position of the "TUNE" control scale in relation to the frequency will be more than enough.

Important: Use an appropriate antenna for the frequency you want to receive and with a 50ohms impedance.

If you want to use antennas with other impedances, then you must use some 50ohms matching system. Although BP-1A is not intended for this, you could use a long wire antenna connected to the high impedance winding of the input toroid, for example at the connection point of C2 and C3 (see schematic) that will correspond to the range of 12 to 30MHz. Obviously this would only serve to work always in the same range since the switching is done on the low impedance side.

SOME SPECTRUM ANALYZER IMAGES

Band-Pass spectrum filter adjusted in some amateur bands:

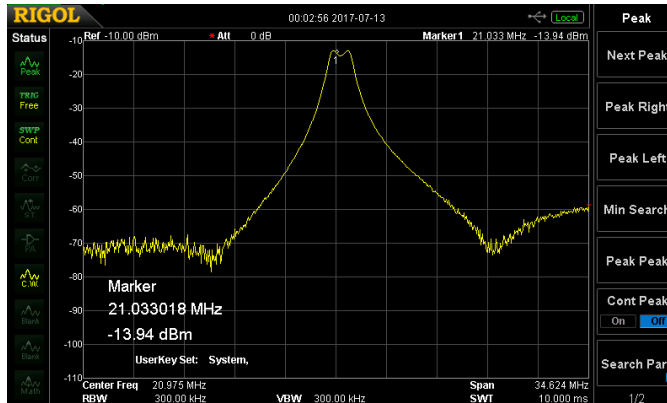
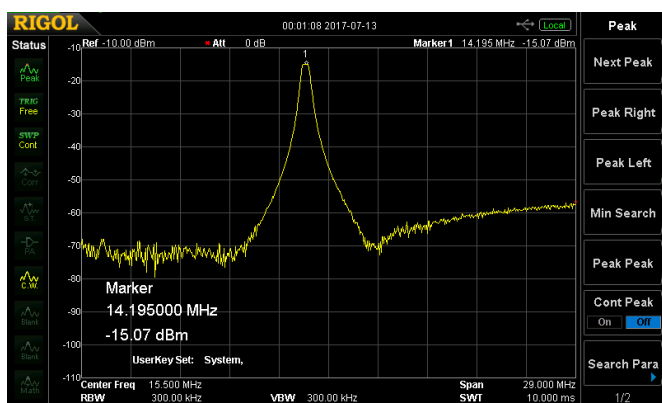
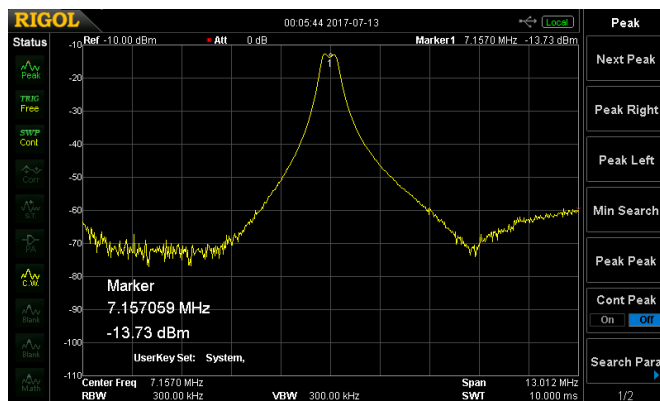
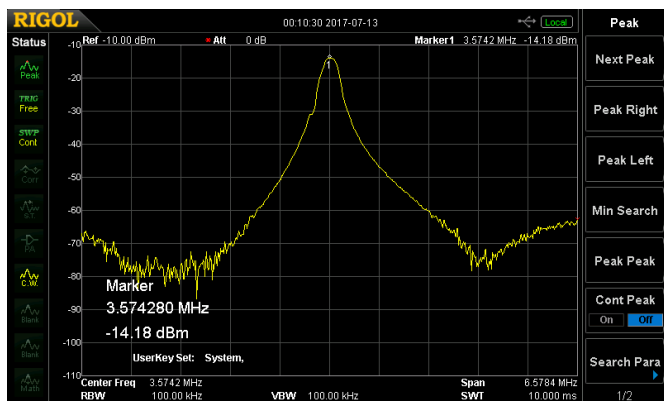

SCHEMATIC

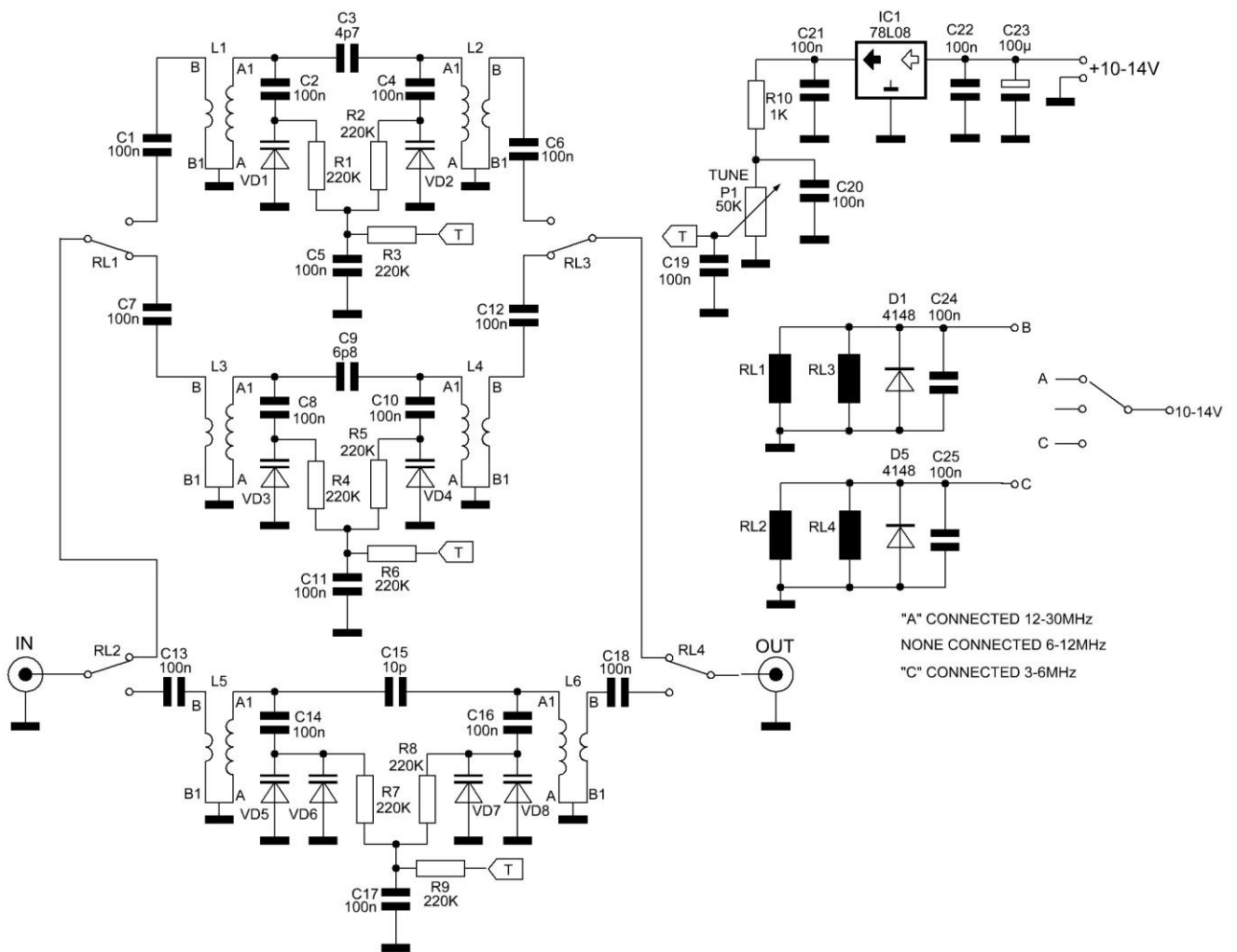

LIMITED WARRANTY

Please read carefully BEFORE building your kit

All electronic components and hardware supplied with the kit are under warranty in case of any manufacturing defect for the period of one year after purchase. The warranty does not include the transmitter final amplifier transistor.

The original purchaser has the option of examining the kit and manual for 10 days. If within this period, the buyer decides not to build the kit, he/she may return the entire unassembled kit, shipping expenses however at their own expense. The shipping expenses and sales commissions (i.e. bank, Ebay, and Paypal commissions) included in the purchase price will not be returned.

Please, BEFORE returning a product, request instructions by email at: ea3gcy@gmail.com.

Javier Solans, EA3GCY, warrants this device to function according to the specifications, provided that it is assembled and adjusted as described in this documentation, and used correctly according to all provided instructions.

It is your responsibility to follow all the instructions in the manual, to identify all the components correctly, and to use good workmanship and proper tools and instruments in the construction and adjustment of this kit.

REMEMBER: This kit will not work as a commercially manufactured product; however, in some situations, it can give very similar results.

If you believe that there is a missing component for the kit, please do a thorough inventory of all parts using the parts list in the manual. Check all bags, envelopes and boxes carefully. If needed, you may email me and I will replace any component that you are missing. Even if you can find the exact part locally, please let me know so that we are aware of the problem to help other customers.

I can also supply any part that you have lost, damaged or broken accidentally.

If you find any errors in this manual or would like to make a comment, please do not hesitate to contact me at: ea3gcy@gmail.com

THANKS for building the **BP-1A** kit.

Enjoy QRP!

73 Javier Solans, ea3gcy