

KB-2

Assembly manual

Last review: April 1, 2020

ea3gcy@gmail.com

Latest updates and news: www.ea3gcy.com

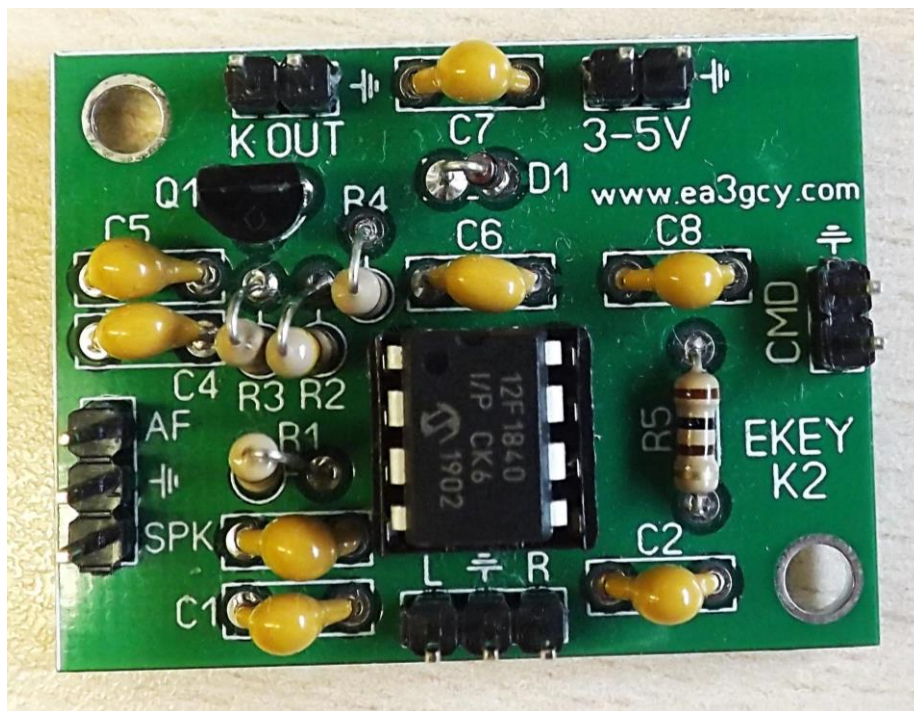

Thanks for purchasing the **KB-2** kit

Enjoy building ! 73 Javier Solans, ea3gcy

PLEASE READ THOROUGHLY ALL THE MANUAL AT LEAST ONCE BEFORE ANY WORK IS DONE.

SPECIFICATIONS

- One single "CMD" command button
- Speed range: 5-50 WPM
- Messages: 4 messages of 60 characters
- Beacon mode: manual or automatic (start as beacon)
- Interval beacon: 0 to 99 seconds
- Modes: A or B
- Reverse paddles command
- Sidetone output on/off
- Adjustable Sidetone frequency
- Key output on/off.
- Quick change of speed by means of the paddles
- "Tune" function. Adjustment of antennas, couplers, etc.
- Power Supply: 3 to 5V
- The KIT includes: PCB and all components + Speaker for Sidetone + 3V battery and socket
- No included: enclosure, switch, cables, or connectors
- PCB Size: 30 x 40mm

PARTS LIST

Parts List					
	Qty	Reference	Value	Part type	Ident.
	2	R1 y R5	100 Ω	resistors 100 Ω	marrón-negro-marrón
	2	R2 y R3	4K7	resistors 4K7	amarillo-violeta-rojo
	1	R4	10K	resistor de 10K	marrón-negro-naranja
	7	C1, C2, C4, C5, C6, C7, C8	100n	Capacitor 100n	104 o 0.1
	1	C3	10n	Capacitor 10n	103 o 0.01
	1	Q1	BC547	Transistor NPN BC547	BC547
	1	D1	1N4148	Diode 1N4148	1N4148
	1	IC1	KB-2 chip	Chip microcontroller KB-2	12F1840
	1	Zócalo 8p		Socket for IC1	--
	2	Separadores	--	Spacers + screws + M3 nuts	--
	12	Pines macho	--	12 pines male	--
	1	Speaker	--	Sidetone speaker	--
	1	Batería	--	Battery 3V CR2032	--
	1	Zócalo batería	--	Battery socket CR2032	--
	1	PCB	--	Printed circuit board 40 x 30mm	--

First part

KB-2 ASSEMBLY

TIPS FOR FIRST TIME BUILDERS

Tools required:

- Small tipped soldering iron of about 25-30 W rating, small side cutters, wire strippers, pliers, long nosed pliers, sharp hobby knife, and screw driver for the M3 bolt.
- You will also need good lighting and a magnifying glass to read the fine print on some parts.

Instrumentation required:

- Multimeter (unessential).

Soldering:

There are two important things which need to be done to ensure the successful operation of a kit: one is to put the right part into the proper place on the board; the other is good soldering.

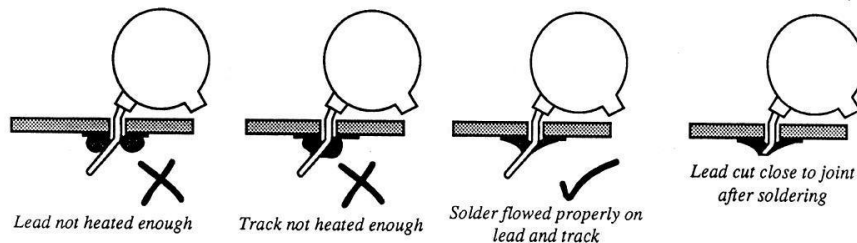

To properly solder you must use the correct type of iron and the right quality of solder. Use a small tipped soldering iron whose bit is short and pointed at the end. The iron should be about 25-30 W (if it is not thermostatically controlled). Only use multicore solder for electronics. NEVER use any extra flux. You should hold the hot iron in contact with both the board and the part lead for about two seconds to heat them up. Then, keeping the iron in place, touch the solder onto the junction of lead and track and wait about two seconds or so until the solder flows along the lead and track to form a good joint. Now remove the iron. The iron should have been in contact with the part and circuit track for a total time of about 4 seconds. It is a good idea to drag the tip of the iron up the component lead as you remove it from the joint, this helps to pull any excess solder up with it and enables good flow along the component lead.

Finding the right part:

IC's

The board outline for ICs has a "U" notch on one end. This indicates the pin 1 end of the IC. There is also a notch on one end of the sockets. This end goes over the "U" notch outline on the board. ICs have usually pin 1 marked with a round dimple or dot. This end of IC will go towards the notch on the socket or "U" on the outline.

Transistors and diodes:

The transistors have the silhouette printed on the board. The diodes must be placed in the correct polarity position, they have a color band on their body that must match the printed drawing on the board.

RECOMMENDED ASSEMBLY SEQUENCE

I strongly recommend that you install the parts in the following order:

1. Following the list of components, solder all resistors R1 to R5. All resistors are placed in vertical position.
2. Then install and solder all capacitors in place.
3. Place the socket for IC1 and insert the integrated circuit KB-2 12F1840. Pay attention to placing them in their correct position. The socket and the integrated circuit have a mark that must match the silhouette printed on the board.
4. Place transistor Q1 and diode D1. The diode is placed in a vertical position and the dark band on its body must match that of the silhouette printed on the board.
5. Place “L-R”, “KOUT”, “3-5V”, “AF-SPK” y “CMD” terminal pin

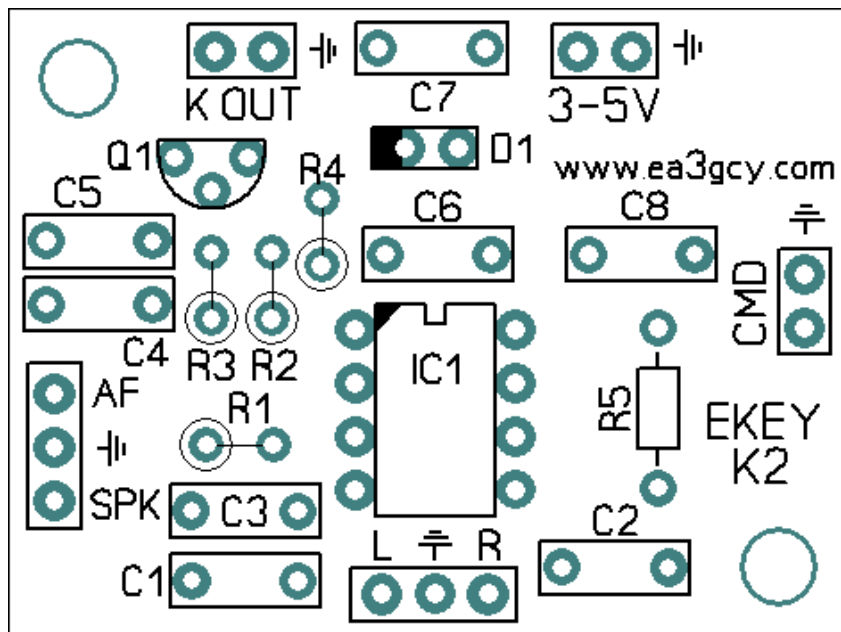

WIRING

The wiring of the KB-2 is very simple. However, keep in mind the following details:

1. For its installation it is advisable to use a metal box.
2. For the input of commands you must use a button with return (normally open).
3. The power should be between 3 and 5V, it is best to use a 3V battery.
4. For the KEY output to the transceiver use a shielded cable respecting the polarization of the signal and GND.

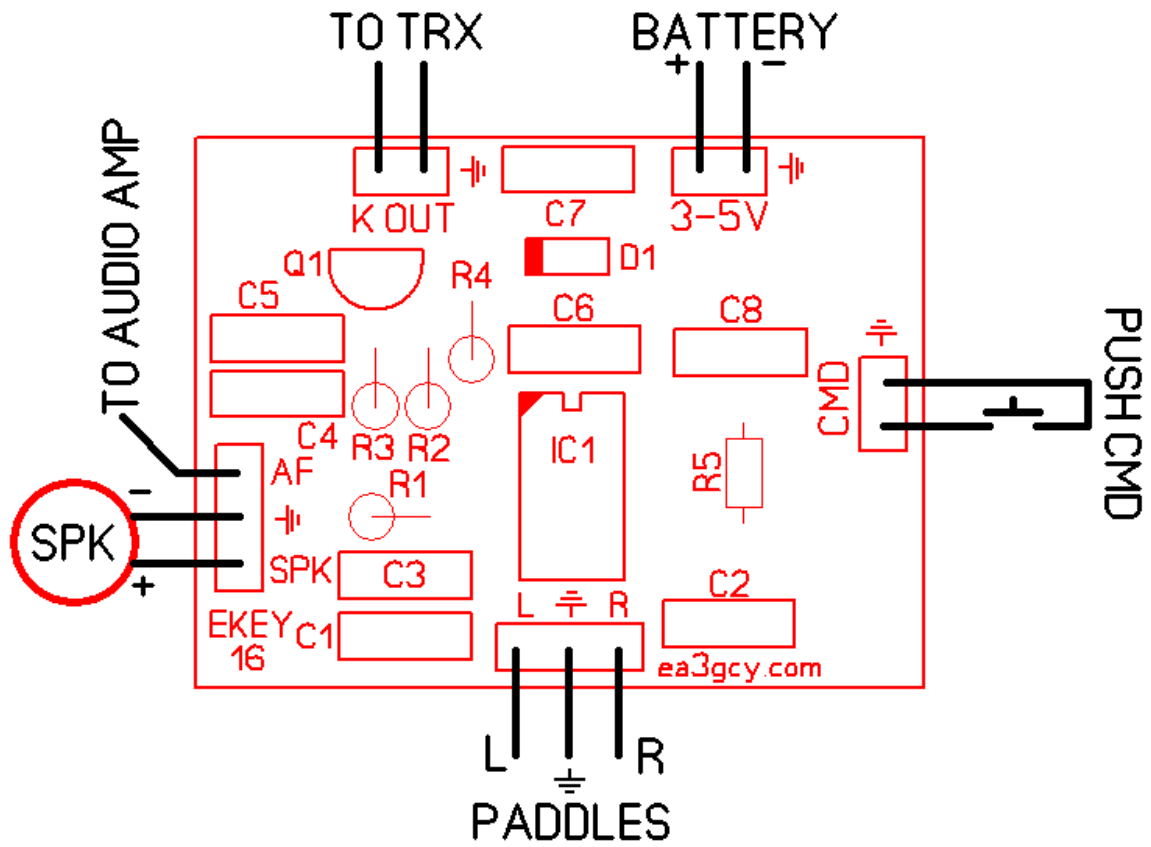

ESQUEMA

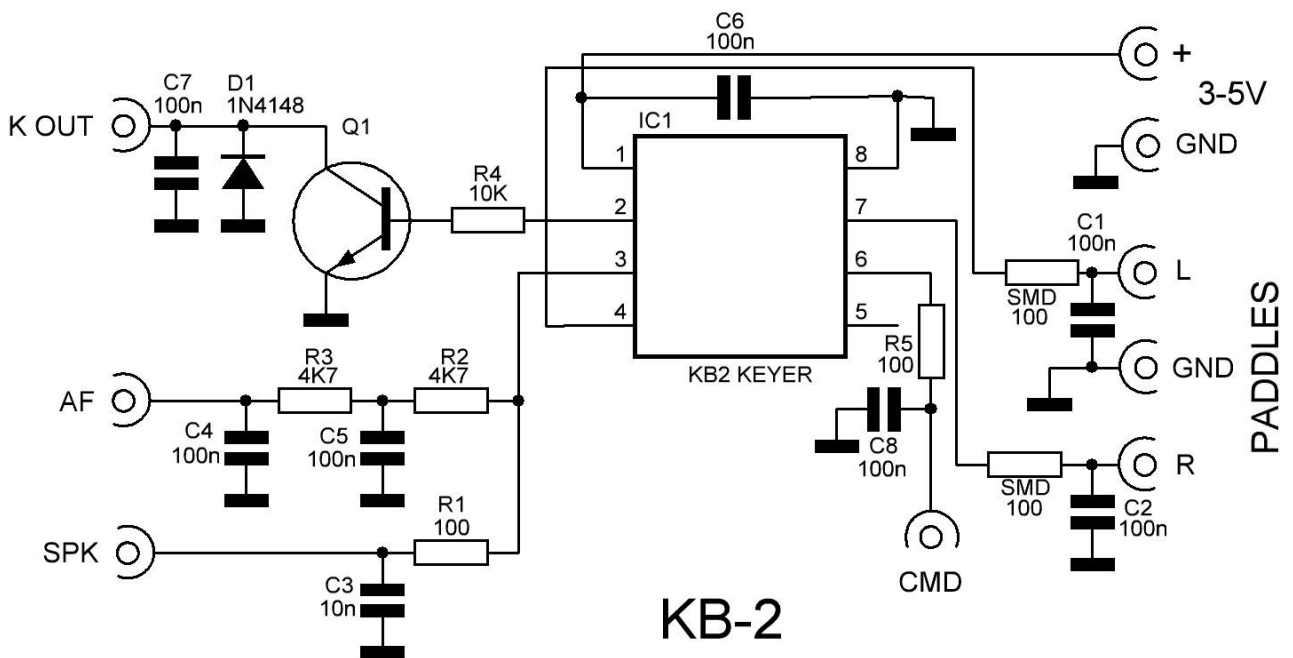

Second part

KB-2 USE

PLEASE READ THOROUGHLY ALL THE MANUAL AT LEAST ONCE BEFORE ANY WORK IS DONE.

NORMAL OPERATION:

Conventions

- When we enter a command, the keyer will respond with "R" (except in the commands that invert the current state, actual "A", "D", "G", "K", "L").
- It will also respond with "R" when we send a digit and do not wait for anything else (example: the message number in the "B" command).
- When the keyer receives a digit that he does not understand or that is not what he expects at that moment, he will respond with "NO".
- The commands and letters or numbers input to programming are always entered with keyer in mode A.
- All commands that make an inversion of the state of a function, if the activation occurs, the keyer responds with "Y" (Yes) and if the deactivation occurs it responds with "N" (No).

Messages playback

The playback is very comfortable and effective, but you should carefully follow the procedure indicated below. Once you have practiced a few times, you will see be extremely simple.

Message 1

Press the CMD button for <1 second. The keyer transmits the message M1.

Message 2

First, press and hold CMD button and before 2 seconds we press and hold the dash paddle, then wait more than >2 seconds. Next, let's release the CMD button first, wait a few moments and then let go of the paddle. Transmission of the M2 message starts.

Message 3

First, press and hold CMD button and before 2 seconds we press and hold the dot paddle, then wait more than >2 seconds. Next, let's release the CMD button first, wait a few moments and then let go of the paddle. Transmission of the M3 message starts.

Message 4

First, press and hold CMD button and before 2 seconds we press and hold both dash and dot paddles, then wait more than >2 seconds. Next, let's release the CMD button first, wait a few moments and then let go of the paddles. Transmission of the M4 message starts.

Stop a message

Press and hold any paddle or CMD button until playback stops.

COMMAND LIST:

Command mode

To enter command mode:

We press the CMD button for more than> 2 seconds until the keyer answers "R" indicating that it waits for command. The keyer waits for 2 seconds for a command to be entered, if nothing is received it sends "NO" and returns to normal keyer mode. If an unknown command is received, it goes out in the same way by sending "NO".

Before entering the letter of the command, you must enter command mode (press CMD until "R" sounds).

"A" Enable/Disable the monitor local tone.

We enter "A". If it was activated, it deactivates it and the keyer sends "N". If it was disabled, will activate it and send "Y".

"B" Indicates which message will act as a beacon.

We program what message the "1", "2", "3" or "4" will act as a beacon.

If we enter "0", no message will act as a beacon.

Enter "B", the keyer answers "R". We enter the message number we want to act as a beacon (1, 2, 3 or 4). The keyer will respond with "R".

To stop the playback of a message in Beacon mode:

Press and hold any paddle or CMD button until playback stops.

Related commands: "C", "D"

"C" Adjust the time between repetitions of the beacon.

Adjust the time between beacon repeats from 00 to 99 seconds

We enter "C" and the keyer responds with "R" and waits for us to enter two numbers from 01 to 99.

Within 2 seconds we have to **enter the first number (tens) and wait for the keyer to respond with an "E"**. Next, we have 2 seconds to **enter the second number (units), then the keyer responds with "R"** and exits the command mode.

Attention: you should always enter two numbers. For example, for 5 seconds you must enter "0" and then "5".

"D" Enable/Disable Automatic Beacon mode.

Enter "D". If it was activated, it deactivates it and the keyer sends "N". If it was disabled, will activate it and send "Y".

The Automatic Beacon makes the keyer always work in Beacon mode when it starts up.

For the automatic beacon to work, the "B" command is used with the message that you want to be the beacon and the "C" command with the time between beacon repetitions.

"E" Adjust PPM speed of the keyer with the paddles.

Enter "E", answer with "R" and then with the paddle dash increase the speed and the paddle dot decrease it. To exit, press and release the CMD button, the keyer will respond with "R".

"F" Adjust the Sidetone monitor frequency.

Enter "F", answer "R". The Dash paddle increase frequency and Dot paddle decrease.

To exit, press and release the CMD button.

"G" Enable/Disable the command and programming monitor on the Key output.

We enter "G". If it was activated, it deactivates it and the keyer sends "N". If it was disabled, will activate it and send "Y".

"K" Change the keyer mode.

Enter "K". If it was in A mode it changes to B mode and vice-versa. Respond with "A" if mode A is activated or "B" if mode B is activated

"L" Enable/Disable KEY output for tests or practices.

Enter "L". If it was activated, it deactivates it and the keyer sends "N". If it was disabled, will activate it and send "Y".

"P" Paddles swap.

Enter "P". The keyer answer "R" and swap the Dash – Dot paddles or vice-versa.

"R" Record the specified memory.

Recording messages is very convenient and effective, but you should carefully follow the procedure indicated below. Once you have practiced a few times, you will see that it will be extremely simple.

To enter messages, you have to change your usual CW transmitting way and listen carefully to the keyer's response signals. To make it easier for messages enter, it may be a good idea to reduce PMM speed ("E" or "S" commands)

Enter to command mode (press CMD until "R" sounds).

Enter "R", the keyer respond us "R". We enter the memory number we want to record (1, 2, 3 or 4), the keyer responds with "R". Next we will enter the message.

The steps to enter a message are the following:

1.- Before 2 seconds we enter a CW carácter (letter, number or punctuation mark).

2.- We hope it sounds a point (letter "E").

We will repeat the previous two steps 1 and 2, entering characters until a word ends

.....

When you want to insert a space between words, do not enter anything after hearing the point (E) and wait 2 more seconds until you hear three points (S) and then continue entering the letters of the next word.

When the message is finished, stop entering anything and wait ... You will hear point (E), then the three points (S) and then you will hear "END",

Each message allows the entry of 60 characters including the spaces between words.

"S" Adjusts the speed of keyer transmission in PPM (from 01 to 50)

We enter "S" and the keyer responds with "R" and waits for us to enter two numbers from 01 to 50. Within 2 seconds we have to enter the first number (tens) and wait for the keyer to respond with an "E" point. Next, we have 2 seconds to enter the second number (units). Then the keyer responds with "R" and exits the command mode.

Attention: You should always enter two numbers. For example, for 8 PPM you must enter "0" and then "8".

"T" Tune.

Enter "T", the keyer respond R and will activate the KEY output. The Dash paddle acts as OFF and the Dot paddle as ON. To exit tune mode, press and release the CMD button

OTHER FUNCTIONS

"RESET"

The RESET has no command. It is done by connecting the KB-1 power supply while pressing the CMD button. The parameters after the RESET are:

Keyer MODE = Mode B
PPM = 15 words / minute
Keyer Output = Enabled
Monitor = Enabled
Output keyer monitor = Enabled
Swap Paddles = Normal
Automatic Beacon = Disabled
Monitor Tone frequency = 800Hz
Beacon = Disabled
Beacon interval repetition = 5 segundos
Messages= It maintains the existing ones before the "reset".

Delete a message.

It is unusual for you to need to delete a message, because when you record a new message, the previous message is deleted. However, if you want to leave a message "blank", enter the "R" command and the message number as if you will record a message normally, but do not enter any character in the message and wait to hear "END". That message will be deleted.

Automatic Beacon Function.

The Automatic Beacon makes the keyer always work in beacon mode when it starts up. This function converts the KB-2 keyer into a universal generator of morse signals for beacon. To work as Automatic Beacon, you must perform the following steps:

- Record the message destined to Beacon in one of the memories ("R" command).
- Then you must select that message to act as a beacon ("B" command).
- Set the interval time between repetitions ("C" command).
- Activate the Automatic Beacon function ("D" command).

Note: if you do not select Automatic Beacon ("D" command) the beacon will act when you press the CMD button, but it will not start automatically when the keyer is turned ON.

Key 2 output

Most keyer users will not use the Keyer 2 output destined to "Mute" the audio on a transceiver. This output is set high (5V) when it is transmitted and has a ½ point delay when it returns to reception (GND) after the keyer's output has finished transmitting.

This output is useful when using the keyer with a "home made" transceiver, this can replace the RX / TX delay circuit that is normally needed for the "mute" of the audio output.

Straight Key function

When the system starts, it check the middle ring of the input jack, if it is connected to GND, then it consider that a straight key will be used. See the image.

That with a straight vertical key you can't enter commands or program the keyer, so you will need a paddles keyer to enter commands and record messages.

However, you can send message 1 "M1" by pressing CMD, to stop playing the message, press CMD again.

Note: You can program a paddle from a paddle keyer to act as a vertical key simply by holding a paddle tight while power up KB-2 circuit (this setting is not maintained when turning off the power to the KB-2 circuit).



Paddles keyer Jack



Straight keyer Jack

LIMITED WARRANTY

Please read carefully PRIOR to do any work with your kit.

All parts provided with this kit are guaranteed against any fabrication defect for one year after the sale. The buyer has the option to examine the kit and the instruction manual for 10 days. If during this period he or she decided not to build the kit, it will be possible to send the kit back, with all shipping charges paid by the customer. The seller shipping charges and all other costs involved (Ebay or Paypal charges) will not be reimbursed.

If you plan to ship it back, PLEASE CONSULT how to do it to ea3gcy@gmail.com

Javier Solans, ea3gcy, guarantees that when the kit is built and adjusted following the information enclosed in this manual, and it is used according to the advices mentioned, it will work according to its specifications.

It is your duty to follow the advices and recommendations of this manual, correctly identify the parts, use good working procedures and have access and correctly use the tools and instruments requirede for the assembly and adjustment of the kit.

In case you think any part for the kit is missing, please make an inventory of all parts with the parts list included on the manual. Please revise all bags, envelopes or boxes carefully. If something is missing, please send me an email and I will mail you the part right away. Even if you don't want to bother with a common part you may have on your junk-box or a local store, please let me know so I can help other customers with a similar problem.

I can also provide a part that you have broken, dammaged or lost by accident.

In case you find any errata or mistake on this manual, or you like to make a comment, please get in touch with me at ea3gcy@gmail.com

Enjoy building EA3GCY Kits !

73 Javier Solans, ea3gcy